

actionair

©RUSKIN AIR MANAGEMENT LIMITED
 South Street, Whitstable
 Kent CT5 3DU
 Telephone: 01227 276100
 Facsimile: 01227 264262
 www.actionair.co.uk

NOTES:

FOR GALVANISED DAMPERS USE CSNN01768 M/STEEL ANGLE CLEATS
 FOR 430 & 316 ST' STEEL DAMPERS USE CUNN02614 316 ST' STEEL ANGLE CLEATS

FOR CORRECT INSTALLATION METHOD PLEASE REFER TO DRAWING RD14520 WHICH DETAILS FIRE TEST 212065 11/04/2003.

FOR MULTIPLE ASSEMBLY DAMPERS, AN ANGLE CLEAT WILL BE WELDED AS SHOWN ON CENTERLINE OF CASING. DAMPERS & JOINING CHANNELS WILL BE SUPPLIED LOOSE, FOR ON SITE ASSEMBLY, BY OTHERS.

THIS DRAWING HAS BEEN PREPARED ON INFORMATION GIVEN TO RUSKIN AIR MANAGEMENT LTD.

THIS METHOD WOULD BE SUBJECT TO THE SCRUTINY AND APPROVAL FROM THE RELEVANT DISTRICT SURVEYOR / LOCAL AUTHORITY PRIOR TO APPROVING AND ORDERING THE PRODUCT DETAILED IN THIS DRAWING. THIS DRAWING IS NOT INTENDED TO ENDORSE THE ARRANGEMENT AS BEING SUITABLE FOR IT'S INTENDED APPLICATION.

THE INFORMATION SHOWN IS SUBJECT TO CHANGE WITHOUT NOTICE DUE TO CONTINUING RESEARCH AND DEVELOPMENT.

Rev	Change	initials	Dates
H	CLEAT DETAIL REVISED	S.W.	28/05/2009
G	NEW CLEAT ADDED, NOTES & TITLE CHANGE	S.W.	12/01/06
F	JOINING CHANNEL DETAILS ADDED	S.W.	18/04/05
E	INFORMATION UPDATED.	A.M.	19/03/02
D	INFORMATION UPDATED.	A.M.	13/02/01
C	HOLE DIAMETER CHANGED FROM 11mm TO 14mm.	M.T.	01/02/93

Drawn By	M.T.	02/05/92
Checked By	H.T.	04/08/2009
Approved By	M.B.	05/08/2009
Customer	N/A	
Project	N/A	

Title DWFX-C G.A. FOR WELDED ANGLE CLEAT.

Drawing No. AA/F 0244 Revision H

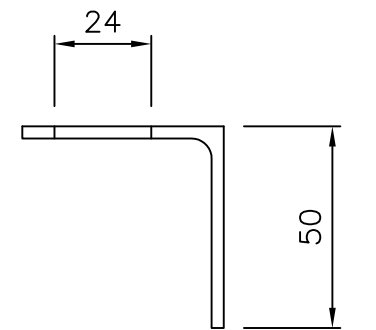
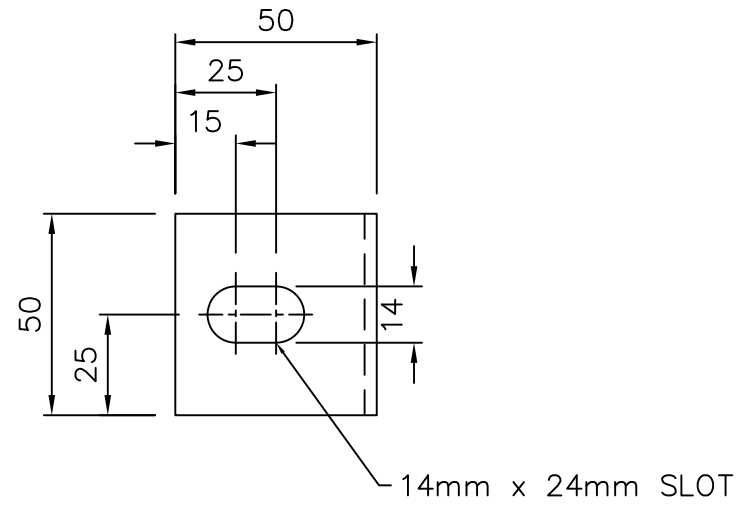

CLEAT DETAIL. (SF028)

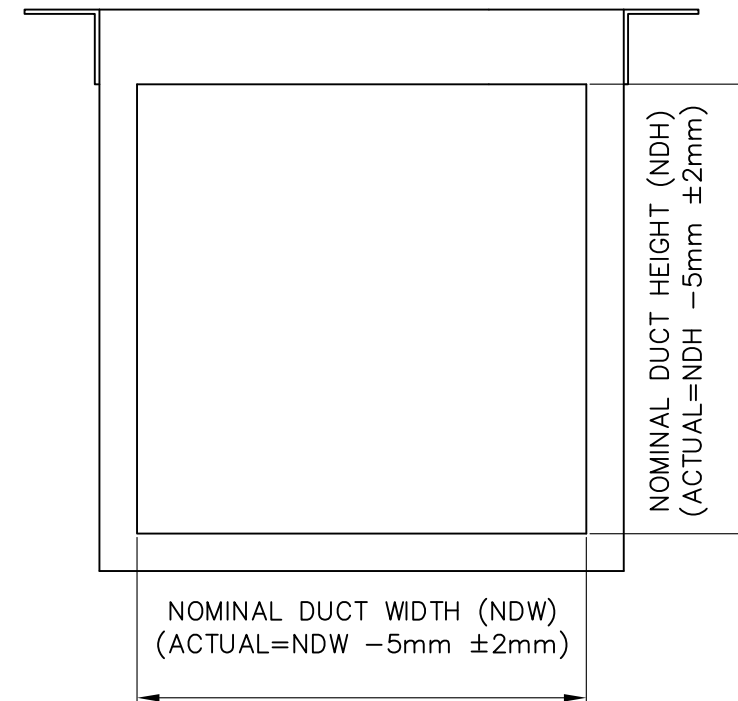
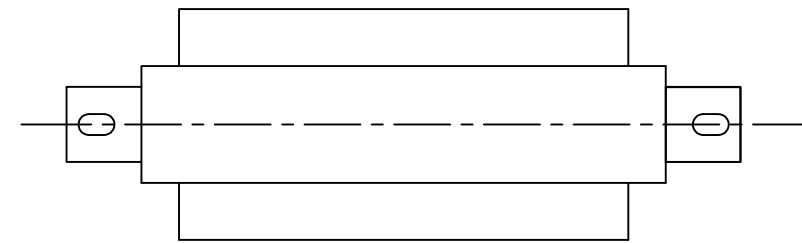
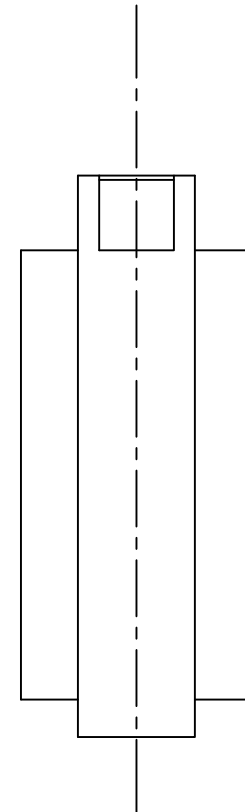

VIEW THROUGH A-A

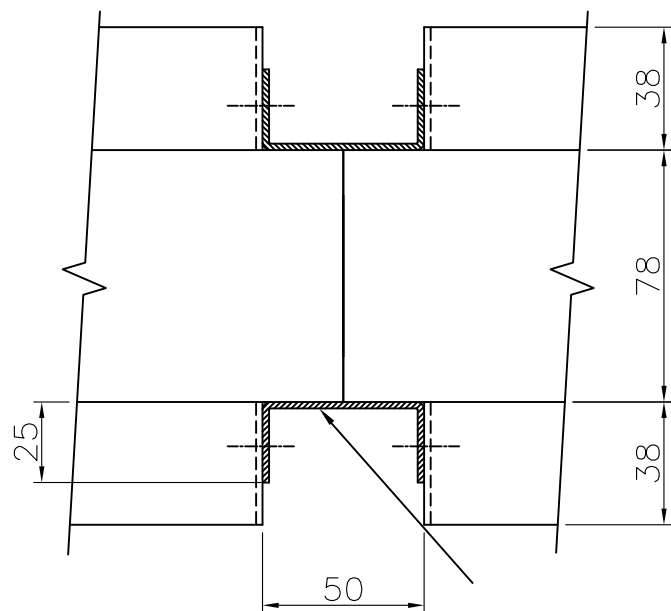

2 OFF JOINING 'U' CHANNEL
 50mm x 25mm x 1.2mm x NDH -10mm
 SUPPLIED LOOSE,
 FITTED ON SITE BY OTHERS.

