

FireShield

Stainless Steel Bladed Curtain Fire Dampers

Features

- Damper tested by LPC/BRE up to 4 hour applications.
- Product Certification Awarded by the Loss Prevention Certification Board Limited. (LPCB).
- Tested to BS ISO 10294-1: 1996, BS EN 1366-2: 1999 and BS 476 Part 20: 1987 Fire Test Standards.
- Corrosion tested.
- Self-Latching Removable Cassette, easy Single Handed Reset.
- Stainless Steel folding curtain.
- Choice of 230V AC or 24V AC and DC remote electro magnet fail-safe releases on cassette type options only.



*action*air

Dampers Controls Fancoils

Ruskin Air Management Limited
www.ruskinuk.co.uk

Dampers Designed and Built
in Britain

The Range

The Actionair FireShield range of quality engineered dampers are suitable for air conditioning and ventilation systems requiring up to 4 hour fire protection.

These stainless steel bladed Actionair FireShield Dampers fail-safe closed and are supplied with the new innovative, even easier Single-Handed Reset Self Latching Removable Release Mechanism Cassette, which permits single handed reset.

Ordinary steel curtain fire dampers involve a complex pull and lift curtain opening operation, further complicated by having to hold the curtain in the fully open position against the constant tension of closure springs whilst attempting to reset or replace the fusible link unsighted.

Specification

FireShield

The Actionair FireShield curtain fire dampers comprising of a stainless steel folding curtain having unbroken movable joints, stainless steel constant tension closure springs for positive closure and stainless steel peripheral gasketing.

The Self Resettable, Latching Removable Release Mechanism Cassette, shall ensure the closure of the stainless steel curtain under full fire conditions. All housed in a galvanised steel fully welded spigotted type casing suitable for square, rectangular, circular or flat oval connections.

FireShield as supplied by Actionair.

(Alternative rated release temperatures to 72 °C are catered for by a chain type link, please refer to Actionair Sales Office for details.)

A Fire Rated Damper in accordance with British Standard 5588: Part 9: 1999 should be held in the Open Position by means of a Thermally Actuated Device set to operate at approximately 74 °C. All FireShield Stainless Steel Curtain Fire Dampers are Fire Rated Dampers as they are held in the Open Position by a Thermally Actuated link operating at a temperature of approximately 72 °C ± 4 °C.

The fitting of a Thermally Actuated Link operating at a higher temperature requires approval by the local relevant Local Authority.

Blade Features

The Type 1.4016 (430) Ferritic Stainless Steel folding blade curtain, providing maximum strength, form a fire shield. The wide profile blades maximise the damper free area and ensure compact grouping to minimise blade stacking height.

Optional blade construction Type 1.4401 (316) Austenitic Stainless Steel.

Side Seal Gasketing

Stainless Steel side seal gasketing provides constant pressure on blade edges, minimising the spread of smoke and other products of combustion.

Ordinary steel curtain fire dampers may not have side seal gasketing.

Stainless Steel Closure Springs

Stainless Steel constant tension springs are fitted and positioned out of the airstream to close and latch the damper, regardless of vertical or horizontal operation.

Casing Features

Spigotted Casing

The spigotted casing with continuously welded corners and spigot connections, makes these dampers suitable for inclusion into air distribution systems to the test methods of Eurovent Class A, B & C and HVCA Ductwork specification DW144.

These galvanised casings are manufactured with either Square, Rectangular, Circular or Flat Oval duct connections.

As an option, casings can be manufactured in Type 1.4016 (430) Ferritic or Type 1.4401 (316) Austenitic Stainless Steel.

Ordinary steel curtain fire dampers for low or medium velocity operation and having the blades and/or part of the casing frame in the airstream may not have casings of continuous welded airtight construction.

Cassette Details

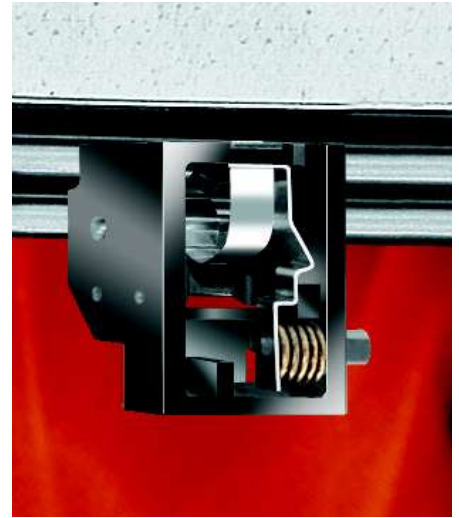

Features

Patented design.

Made of Polyphenylene sulphide (PPS) resin reinforced with 40% glass (GF-PPS).

Technically advanced engineering polymer.

PPS is stable at temperatures up to 200 °C.

Cassette construction is of very high strength and has excellent creep and fatigue resistance.

Low smoke and toxic emissions in fire conditions.

Halogen free.

PPS has a very low moisture absorption.

PPS is corrosion resistant.

The Cassette construction is environmentally friendly (recyclable material).

The new Cassette is retrofittable to existing FireShield Dampers (by use of a simple optional adaption bracket). Part Number: C>NNN01981

One Cassette to suit all damper material options.

Self Latching Removable Release Mechanism Cassette

The cassette mechanism is completely removable from the FireShield Damper by manually releasing the retaining clip **1**. This allows replacement of the cassette without the use of tools **2**.

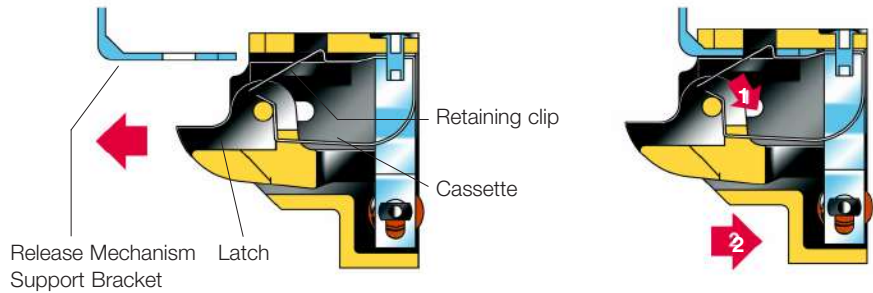

Simple hand operation enables the damper curtain to be reset and latched in the fully Open Position. This increases the ease and speed with which the FireShield Damper can be reset following periodic functional testing in accordance with British Standard BS 5588: Part 9 Code of Practice for Ventilation and Air Conditioning Ductwork.

Set Position

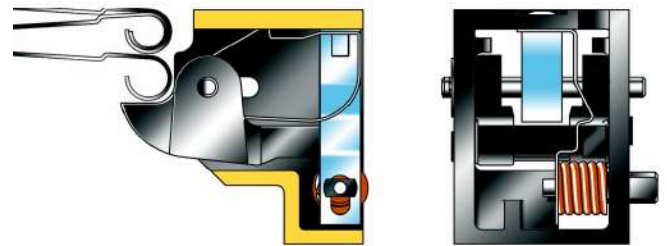

The thermal actuator in the form of a helical memory metal compression spring is produced from a special Cu-Zn-Al brass alloy.

Manual Operation

Manual Operation for periodic functional testing in accordance with British Standard BS 5588: Part 9 Code of Practice for Ventilation and Air Conditioning Ductwork.

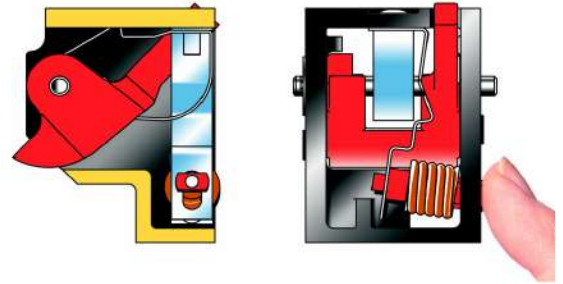

On temperature rise this expands and at 72 °C, causes the FireShield damper blades to release.

Thermal Actuator Operation

Memory metal coil springs, specially designed to fully expand at 72 °C and actuate damper closure.

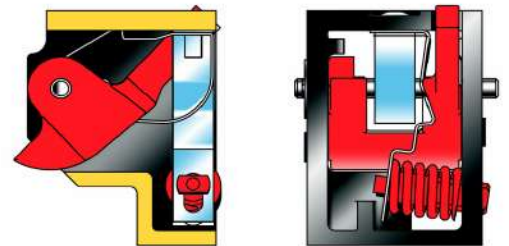

On cooling, the spring reverts to the close-coiled state offering the significant advantage of repeated operation, unless it has reached temperatures in excess of 170 °C, where it will remain extended, preventing reset.

Remote Release Operation

Remote release operation to close the FireShield Damper is by Bowden cable with Manual action or Electrical 230V AC or 24V AC and DC Electro Magnet fail-safe action and independent of the thermal actuator. Bowden outer sleeve can be fitted from either side of cassette

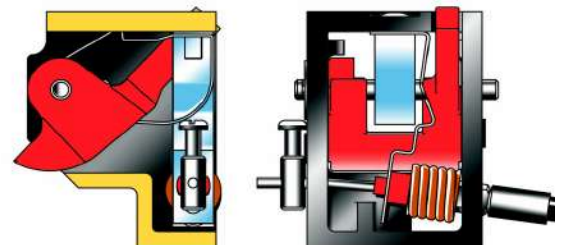

Cassettes are only available for 72 °C. For Dampers where alternative thermal link temperatures are required a chain-link can be offered in place of a cassette. Electrical release is only available with a cassette i.e. 72 °C. Please refer to Actionair Sales Office.

Reset Operation

Single hand operation. Each blade pushes the latch back under spring tension. On full blade reset the latch springs out to secure.

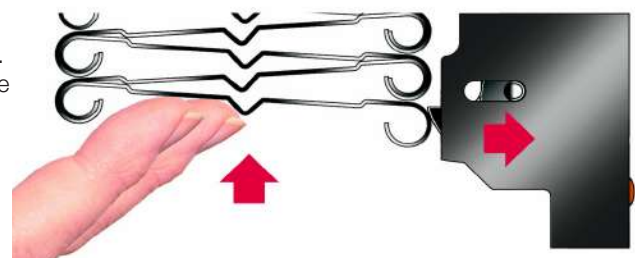

Please note: For dampers with dimensions of 150mm and below ensure that there is adequate access to enable re-setting.

External Visual Blade Position Indication

An external indicator is factory fitted to the access (cassette) side of the damper casing giving visual indication of damper blade position.

A spring steel actuator ensures automatic resetting of the external indicator in either horizontal or vertical applications.

The external indicator is especially beneficial at the system balancing and commissioning stage eliminating the necessity of internal duct inspection to determine the fire damper open or closed position.

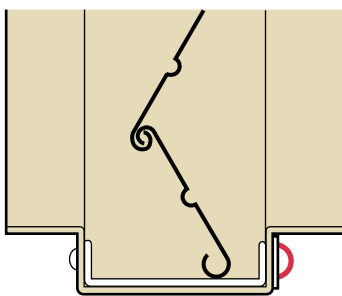
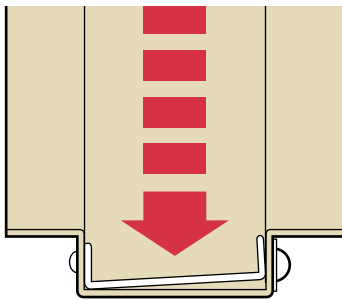

Fluorescent Red Display

Indicating damper blades in closed position.



Note: External visual blade position indication is not available with special finished casings, certain multiple assemblies, miscellaneous Damper configurations and due to physical size limitations is not available below 125mm dia. on Series 301 Dampers.

Multiple Assemblies

Square and rectangular casings are available in multiple module arrangements, supplied complete with connecting channels for site fixing by others.

Multiple Vertical Arrangement

Series 201 or 101 as required mounted on Series 101 can also be arranged 3 off dampers high to give maximum duct height of 3100mm. Duct width as required. Bottom dampers only provided with external visual indication of blade position.

Note: Should more than 3 off dampers high be required, adequate damper supports are necessary and must be provided. Please refer to Actionair Sales Office.

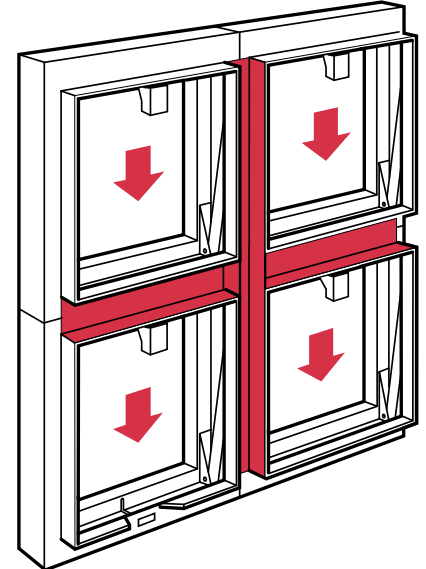

Multiple Vertical Arrangement

Series 101 shown. Series 201 can be mounted similarly. Maximum duct height 1000mm. Maximum duct width as required. Horizontal arrangement similar. External visual indication of blade position provided with all dampers.

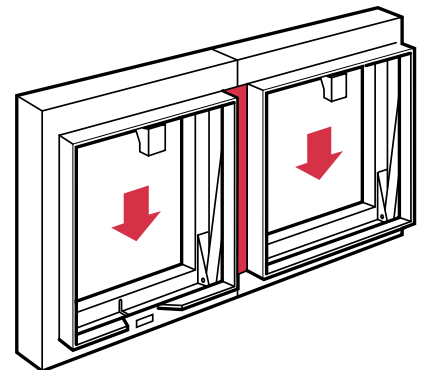

Multiple Horizontal Arrangement

Series 201 shown. Series 101 can be mounted similarly, four or more sections. Maximum duct height 2050mm. External visual indication of damper blade position not relevant to this application.

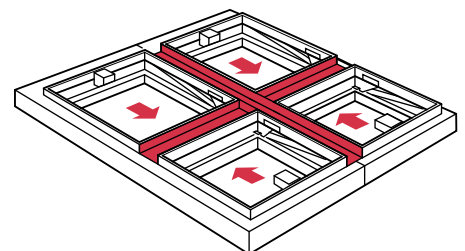

Remote Electrical Fail-Safe Releases

Electro Magnet Releases

230V AC and 24V AC and DC Electro magnet releases are available, for use with cassette mechanisms only.

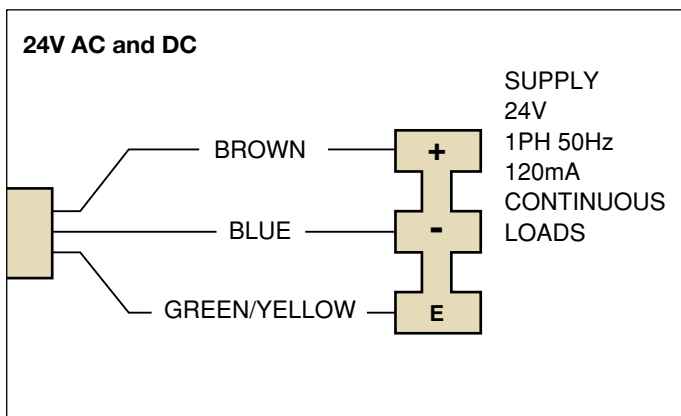
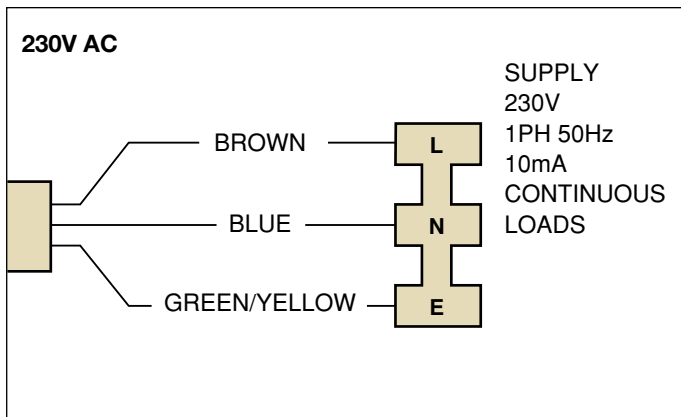
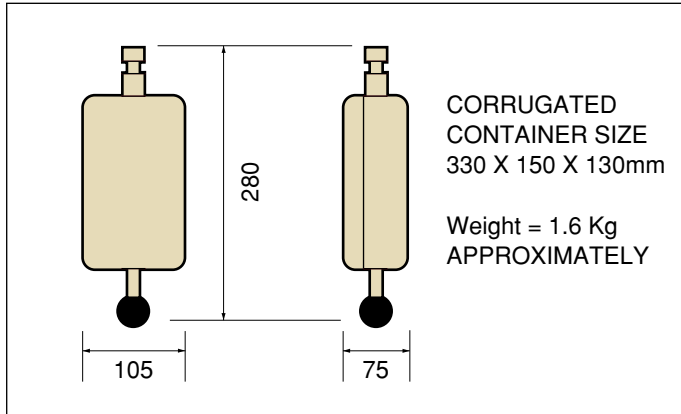

Terminal blocks supplied by others.

Indication Micro Switches

Micro Switches

All Series FireShield Dampers are available with factory fitted single or double pole micro switches as optional extras to provide remote electrical indication of damper status and/or controls interface.

Standard Fitment Option 'M' Type Single Pole

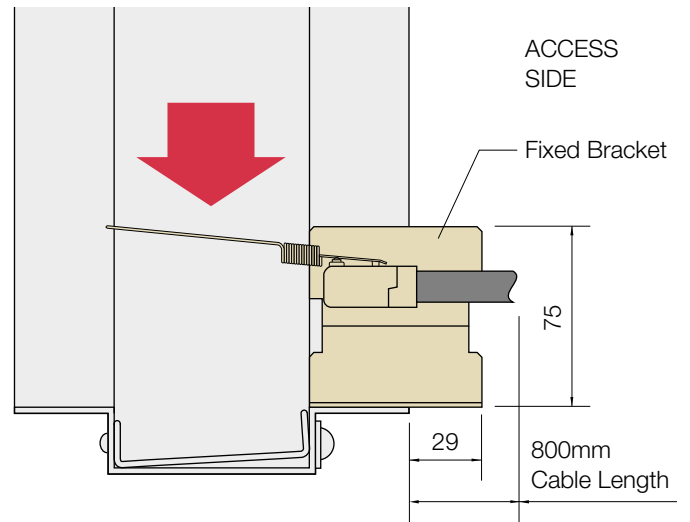

Heavy Duty Option 'T' Type Single Pole

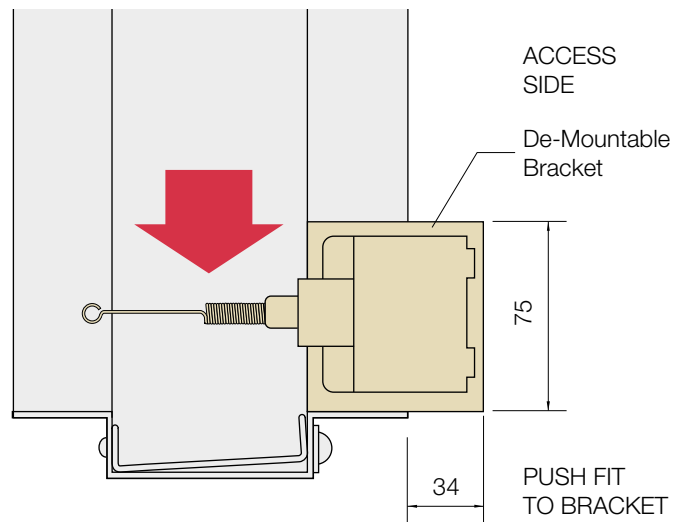

Note: For Dampers below 200 x 200mm or 200mm diameter micro switches will be factory fitted on the non access side.

Installation Systems

Popular types of Installation Frame that are available.

DWFX™ (DRY WALL FIX) Installation System

Typically for installation into Dry Wall, Stud Partitions.

HEVAC / HVCA Galvanised Steel Installation Frames

Typically for installation into Blockwork, Concrete walls and floors.

Cutting Hole Size

Measure damper casing.

Cutting hole size =

Width = 2 x wall board thickness used
+ 2 x 12.5mm clearance all round
+ damper casing width.

Height = 2 x wall board thickness used
+ 2 x 12.5mm clearance all round
+ damper casing height.

Hole tolerance of +/- 5mm applies.

Example

Nominal FireShield damper 1000mm x 1000mm using 12.5mm wall board thickness.

Measure casing of damper (1048mm Wide x 1123mm High).

+ 2 x 12.5mm clearance = 25mm
+ 2 x 12.5mm wallboard = 25mm

Therefore cutting hole size = 1098mm Width x 1173mm Length.

DWFX-F Dimensional Data

See page 8

DWFX-C Dimensional Data

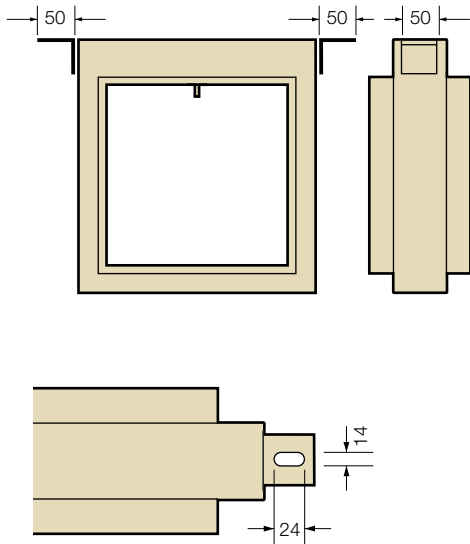

DWFX-F (Dry Wall FIX - Frame)



Specification

The Actionair DWFX-F installation method is BRE Tested to EN1366-2 for 90 minutes. (BRE test report 220895).

Classification (ref BRE assessment 225285).

- Actionair FireShield E90
- Actionair SmokeShield ES60/E90
- Actionair HotShield ES60/E90

The Actionair DWFX-F consists of a 1.2 mm galvanised steel peripheral flange with 50mm x 50mm x 3mm steel angle cleats with 14 x 24 oval slots, welded to damper flange for drop rod support.

DWFX-C (Dry Wall FIX - Cleat)



Specification

The Actionair DWFX-C installation method is BRE Tested to BS476 pt 20 for 2 hours. (BRE test report 212065).

Suitable for

- Actionair FireShield
- Actionair SmokeShield
- Actionair HotShield

The Actionair DWFX-C consists of 50mm x 50mm x 3mm steel angle cleats with 14 x 24mm oval slots.

Fully welded to damper casing for drop rod support prior to wall construction.



Comprehensive literature, outlining installation and features, is available for our DWFX systems. Go to our website:-

www.actionair.co.uk

to view or download these as PDF files.

HEVAC / HVCA Galvanised Steel Installation Frames

Galvanised steel building ties permit stable handling, ease of transport and convenience of building in to the surrounding structure.

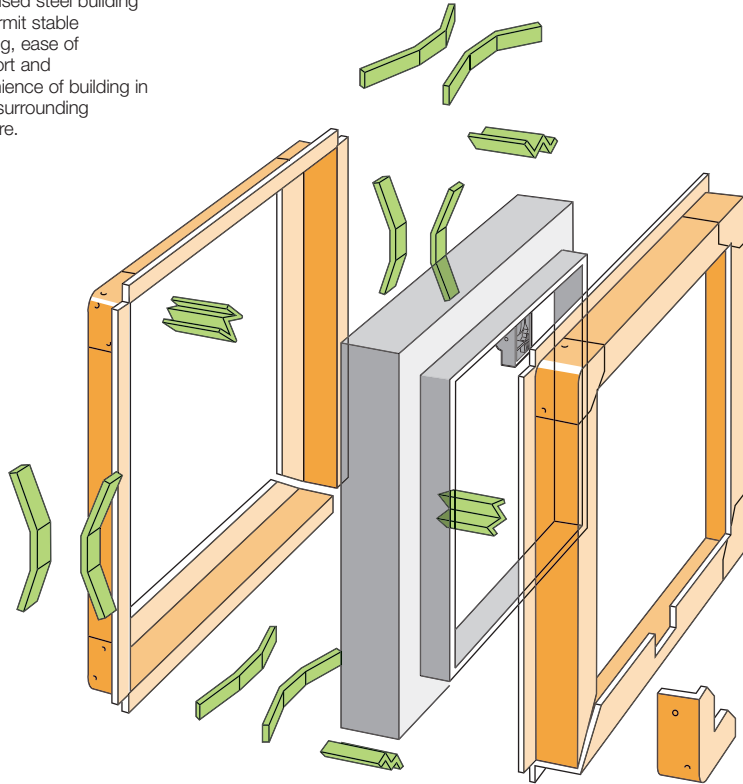

Galvanised Steel Installation Frames
(as required by HVC 6/5/83 Rev.1 July 1999.)

Installation frames are delivered to site as a complete assembly with the appropriate FireShield Damper fitted therein. The frame shall be installed centrally in the thickness of a brick, blockwork or concrete surrounding wall or floor, or in the case of thick walls or floors, so that the centre line

of the frame is at least 50mm away from the nearest face of the wall or floor in which the assembly is mounted. **The four tabs (building tie) forming each fixing point shall provide a positive fixing into the structure.** Multiple assembly dampers up to 1500 x 1500 or 2000 x 1000 can be fitted into fully assembled installation frames and delivered as one piece. Dampers in excess of this size will be

supplied in sections with the installation frame supplied in kit-form, AAF Drg.8057. A drawing and method statement will be supplied for the assembly to be fitted on site.

The maximum size of kit-form installation frames will be to accommodate a four section assembly.

- a. In brick or blockwork walls the tabs shall be bent out and solidly built into the mortar joints between the brick or blockwork.
- b. In the case of reinforced concrete walls and floors, the tabs shall be bent out and tied with wire to the reinforcing bars which will be deliberately left protruding into the opening.

The gap between the installation frame and builders work shall be backfilled with mortar or concrete on both sides of the flange.

Adjacent frame assemblies must be separated by builders work of a minimum thickness of 225mm (between installation frame upstand flanges) unless approval has been previously obtained from the appropriate Authority. For installations below this dimension please refer to Actionair Sales office.

In no case shall the HEVAC/HVCA frame and damper assembly be held in position merely by the adjacent ductwork, and it should be noted that in reinforced concrete structures (especially floors), it will not be sufficient to only backfill between the damper installation frame and the surrounding opening with mortar or fine aggregate concrete mix without provision for tying in the frame to the surrounding reinforced concrete structure.

Approved Installations

A binder containing approved installation illustrations is now available.

(Refer to Actionair Sales Office or visit our website, www.actionair.co.uk The illustrations are under the heading PRODUCTS DRAWINGS.)

Although the included methods have been tested and assessed, it is recommend, that these, as with all installation methods must be confirmed with Building Control /

Local Authority prior to manufacture. Actionair can also provide applications of other proposed methods of installation, please contact our Sales Office to discuss your specific requirements.

These again are the responsibility of the client to ensure that these are acceptable to Building Control / Local Authority before construction commences.



Dimensional Data

Basic Dampers

Series 101 FireShield Dampers with blades partly in airstream (Damper spigots 5mm under duct size) *100- – 249 high, blades effectively outside airstream

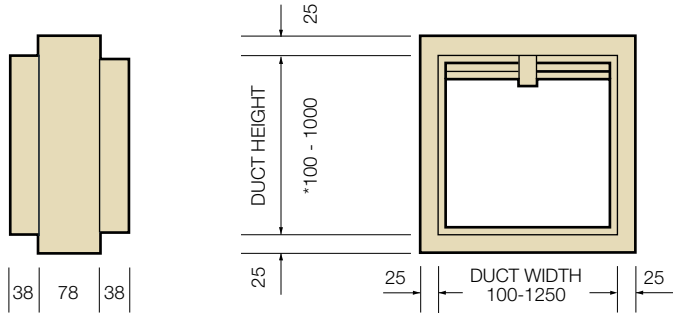

Series 201 FireShield Dampers with blades effectively outside airstream (Damper spigots 5mm under duct size) *100- – 249 high, use Series 101 Damper as blades effectively outside airstream

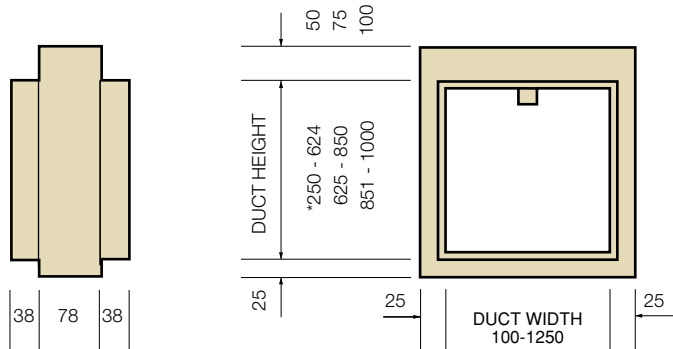

Series 301 FireShield Dampers with blades effectively outside airstream (Damper spigots 3mm under duct size)

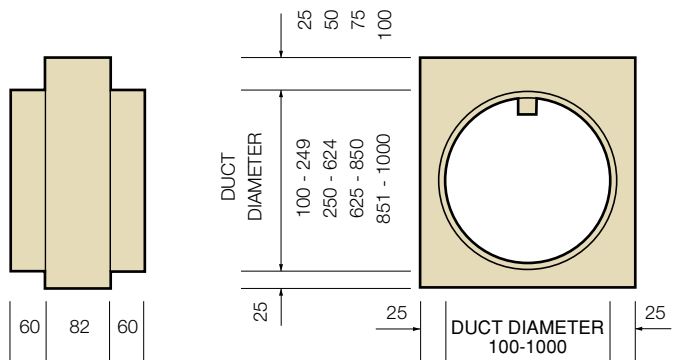

Series 401 FireShield Dampers with blades effectively outside airstream (Damper spigots 3mm under duct size)

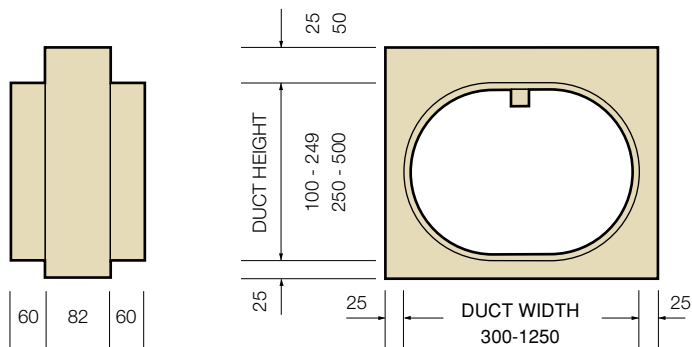

Dampers with Installation Systems

Dampers with DWFX-F

* For cutting hole size see page 6.
Based on 12.5mm wallboard

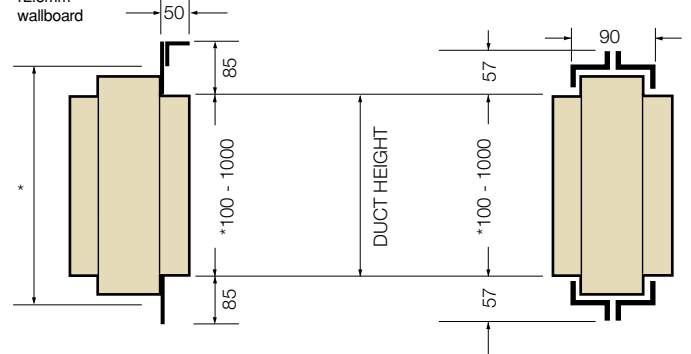

* For cutting hole size see page 6.
Based on 12.5mm wallboard

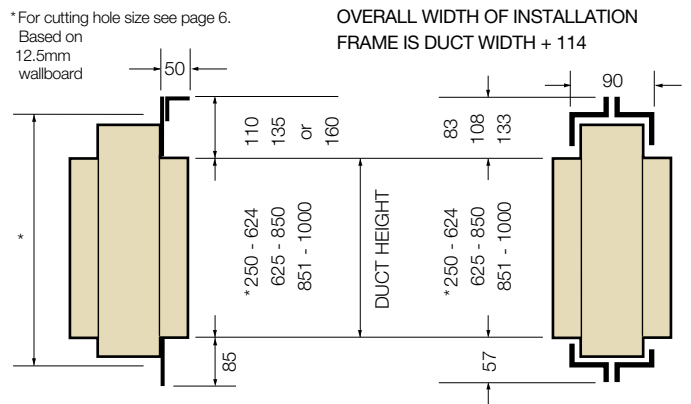

* Cutting hole size DW + 100, DH + 100 + 25, 50 or 75mm

* For cutting hole size see page 6.
Based on 12.5mm wallboard

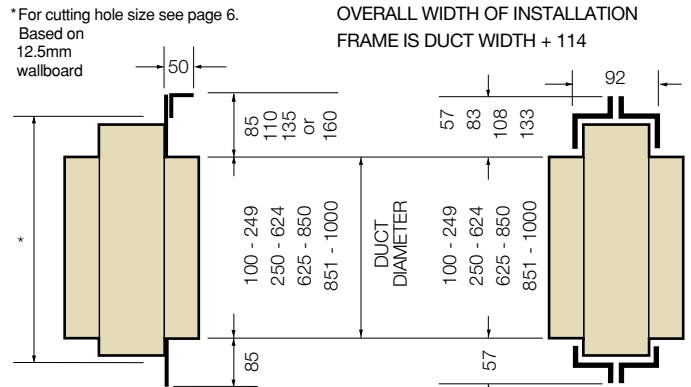

* Cutting hole size W = dia + 100, H = dia + 100 + 0, 25, 50 or 100mm

* For cutting hole size see page 6.
Based on 12.5mm wallboard

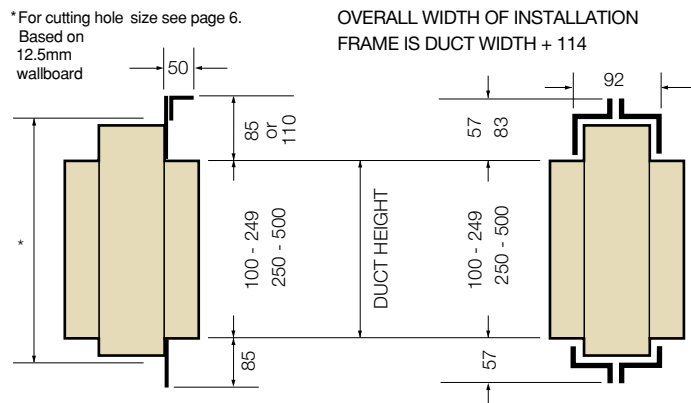

* Cutting hole size DH + 100, DH + 100 + 0, or 25mm

Acoustic Data

The data presented is from the Laboratory Determination of Acoustic and Aerodynamic Performance of FireShield Stainless Steel Curtain Fire Dampers.

A programme of extensive tests was carried out in the Reverberation Chamber and North Transmission Chamber of Sound Research Laboratories Limited, Holbrook Hall, Sudbury, Suffolk, generally in accordance with BRITISH STANDARDS Nos., 4196, 4773, 4856, 4857 and 4954.

This independent test facility is approved under the NAMAS Scheme.

For a selection of duct velocity within the operational parameters of the dampers a resultant pressure drop can be determined and the sum of these two components applied to the Velocity X

Pressure Drop Vs Sound Power Level Graph. The Sound Power Level Graphs are a result of a full range of acoustic tests on FireShield Series 101, 201 and 301 dampers. The Spectrum Correction Data is applied to the number obtained from the graph and a complete Sound Spectrum of Flow Generated Noise for both Breakout (casing radiated) and Outlet (in duct) is obtained.

Velocity (m/s) X Pressure Drop (Pa) Vs Sound Power Level (dBW)

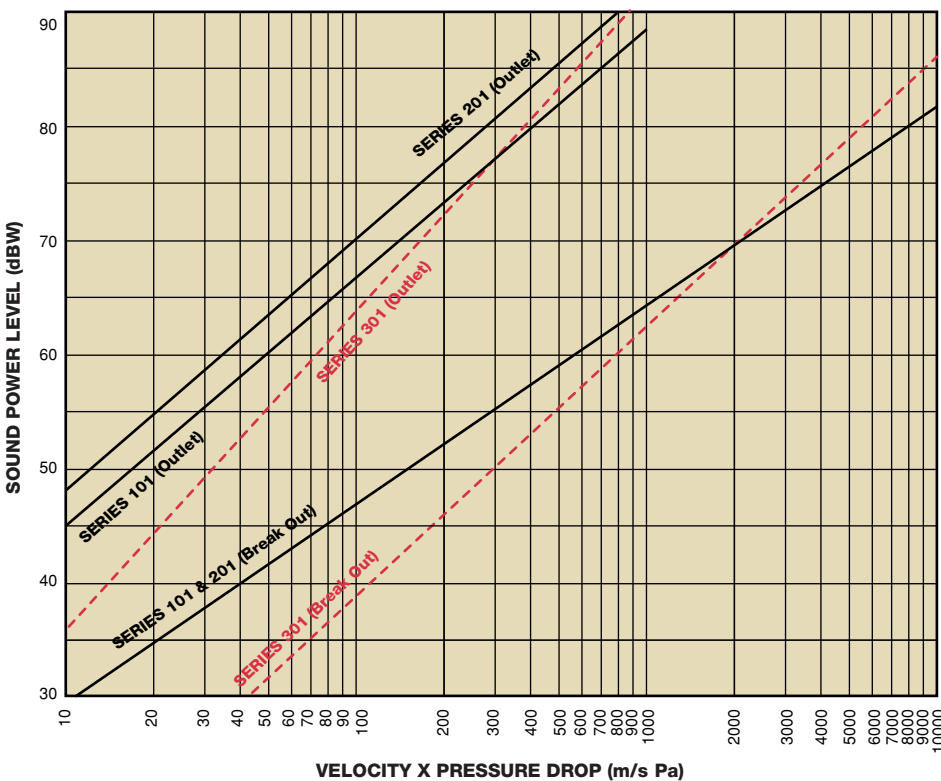

Pressure Drop Vs Velocity

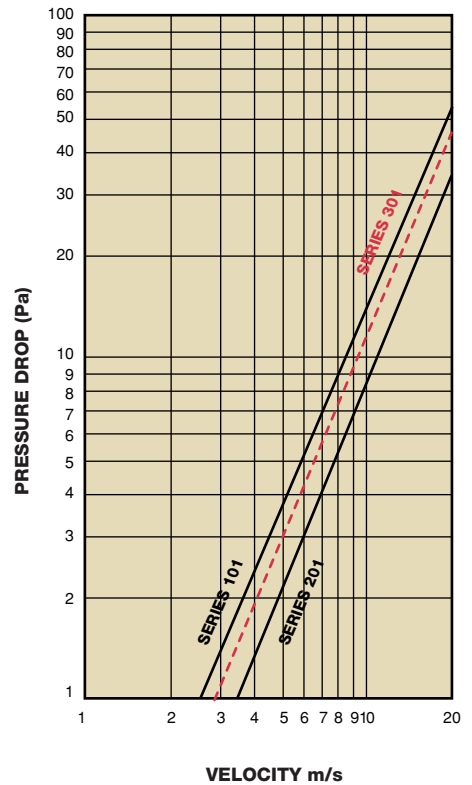

FireShield Breakout Spectrum Correction

Octave band	63	125	250	500	1K	2K	4K	8K	Hz
SERIES 101	-10	-7	-3	-9	-13	-20	-30	-33	dB
SERIES 201	-10	-7	-3	-9	-13	-20	-30	-33	-dB
SERIES 301	-13	-10	-3	-7	-11	-12	-26	-42	-dB

FireShield Outlet (Induct) Spectrum Correction

Octave band	63	125	250	500	1K	2K	4K	8K	Hz
SERIES 101	-4	-12	-16	-18	-22	-29	-32	-38	dB
SERIES 201	-4	-11	-17	-19	-22	-30	-33	-40	dB
SERIES 301	-4	-10	-16	-18	-21	-24	-30	-38	dB

Application Parameters

FireShield Dampers are designed for application in normal dry filtered air systems. If exposed to fresh air intakes and/or inclement conditions the damper should be subject to a planned inspection programme.

Any specialists and/or aggressive applications (e.g. swimming pools) may invalidate our warranty, please refer to Actionair Sales Office.

Customer Service

Actionair provides quality products backed by a dedicated team committed to providing the very best in customer service.

Offering experienced technical backup, comprehensive sales and administrative customer support, product commissioning and maintenance service.

Testing and Maintenance

FireShield Dampers are designed for applications in normal dry filtered air systems and should be subjected to a planned inspection programme, with cleaning and light oil lubrication in accordance with good industry practice.

All FireShield Dampers should be tested by competent persons on completion of the installation and at regular intervals not exceeding two years.

Spring operated fire dampers should be tested annually and fire dampers situated in dust laden and similar atmospheres should be tested much more frequently, at intervals suited to the degree of pollution. (All in accordance with BS5588-9 1999 Test Frequency).

Quality Assurance



Certification No. 172
Assessed to ISO 9001



For further application, technical and pricing information, please refer to Actionair Sales Office.

Approximate Weights (Kg)

Square or Circular Duct Size (mm)	100	150	200	250	300	350	400	450	500	550	600	650	700	750	800	850	900	950	1000
Series 101	1.6	2.1	2.8	3.5	4.2	5.0	5.7	6.9	7.5	8.6	9.5	10.9	12.0	13.1	13.8	15.2	16.7	18.1	19.0
Series 101 + I/F	3.8	4.6	5.7	6.8	8.0	9.2	10.7	11.8	12.9	14.1	15.8	17.9	19.1	20.2	21.3	23.3	25.2	27.4	29.2
Series 201	Please use series 101 dampers for duct heights below 250mm			4.1	4.6	5.4	6.0	7.1	8.0	9.3	10.5	12.1	12.7	14.4	16.0	17.5	19.0	20.5	22.0
Series 201 + I/F	Please use series 101 dampers for duct heights below 250mm			7.4	8.5	9.6	10.4	12.6	13.8	15.3	16.8	18.0	20.3	21.7	23.6	25.5	27.6	29.8	32.0
Series 301	2.3	3.0	4.0	5.4	6.5	7.6	8.8	10.2	11.7	13.2	14.9	16.9	18.7	20.5	22.4	24.5	26.7	28.8	31.0
Series 301 + I/F	4.4	5.5	6.9	9.0	10.4	11.7	13.6	15.5	16.5	18.5	20.3	22.2	42.5	27.8	30.4	32.8	35.2	38.9	42.0

Ordering Information

Example

Quantity	Series	Duct Size	Installation Option	Accessories.
2	FS201	1000(W) x 600(H)	IF	EM240
Number of units required	<p>FS101 Square/Rectangular (blades partly in airstream).</p> <p>FS201 Square/Rectangular (blades outside airstream).</p> <p>FS301 Circular (blades outside airstream).</p> <p>FS401 Flat Oval (blades outside airstream).</p>	Nominal Damper Spigot Size	<p>IF Installation Frame</p> <p>DWFX-C™ Drywall Fix Cleat</p> <p>DWFX-F™ Drywall Fix Flange plus Cleats</p>	<p>EM240 240V AC Electromagnet release. XNNN00009</p> <p>EM24 24V AC and DC Electromagnet release. XNNN00008</p> <p>MSSP 'M' Type Single Pole microswitch. JNNN00011 'T' Type - Heavy Duty Single Pole. DNNN00005</p> <p>MSDP Double Pole microswitch. 'T' Type - Heavy Duty Double Pole. DNNN00011</p> <p>Note: 1 off each of above per damper section.</p>

**Ruskin Air Management Limited
is a ISO 9001 and 14001 registered
company.**

The statements made in this brochure or by our representatives in consequence of any enquiries arising out of this document are given for information purposes only. They are not intended to have any legal effect and the company is not to be regarded as bound thereby. The company will only accept obligations which are expressly negotiated for and agreed and incorporated into a written agreement made with its customers.

Due to a policy of continuous product development the specification and details contained herein are subject to alteration without prior notice.

**Comprehensive and detailed information
is available for all Actionair products.
Visit our website at www.actionair.co.uk**

Ruskin Air Management Limited



South Street, Whitstable, Kent
CT5 3DU England.
Tel: 01227 276100
Fax: 01227 264262
Email: sales@actionair.co.uk
Website: www.actionair.co.uk

actionair

Dampers Controls Fancoils