

# Actionpac LNS3

Intelligent Damper Control and Monitoring System

## Range and Features

- All system wide activity is logged and viewable for diagnostics and preventative maintenance
- Devices powered by closest distribution board
- Flexible system architecture
- Full diagnostics for system and device integration from Panel PC
- RS232 BMS link provided
- Simple Graphical User Interface displays all live system activity, including damper and input/output details/status as well as cause and effect programming
- Solid State Panel PC
- Subsystems supported from one panel
- Text fields facilitate clear description of device references and locations
- Will control and monitor many variants of motorised Dampers
- 2 core network cable, utilising daisy chain method of wiring to all devices, offering reduced wiring costs



Recessed version shown

*action*air

Dampers Controls Fancoils

Ruskin Air Management Limited  
[www.ruskinuk.co.uk](http://www.ruskinuk.co.uk)

## Smoke... the silent killer

### Introduction

Consultants in the field of fire engineering have long recognised the damage and danger to human life that can be caused by smoke spreading through buildings, even when the fire is confined to a small area.

Smoke/fire protection can save human lives as well as keeping damage to property and contents to an absolute minimum.

Control measures for smoke/fire protection, in old and new buildings, comprise a wide variety of systems and items of equipment that must be carefully integrated in order to ensure maximum safety.

One of the most important tasks is performed by the automatic smoke and fire dampers that are incorporated into HVAC systems. In an emergency they must close immediately to contain the smoke and fire and prevent their spread through the ducting or open immediately to allow smoke extraction to take place.

The Actionpac LNS3 system represents a new generation of smoke/fire damper control. The system has been designed with the user in mind, providing an advanced tool that simplifies installation and commissioning of smoke/fire dampers and peripheral devices. The Panel PC operates on an embedded

platform and utilises solid state technology for optimum reliability.

It's server architecture delivers new benefits such as reduced commissioning time, simplified operation and scope for future growth.

#### The Actionpac LNS3 Intelligent Smoke and Fire Damper typical Control System application.

The Actionpac LNS3 system is designed to protect life and property from damage caused by smoke and fire, by providing the means to:-

- Compartmentalise fire zones.
- Reduce the spread of smoke and fire.
- Keep escape routes and fire-fighting access open.
- Allow pressurisation and smoke extract by combined operation of dampers and fans.

Ⓢ Denotes Automatic Smoke and Fire Damper in smoke containing mode on the first floor whilst offering pressurisation to other floors including the stairwell.

⊕ = Positive Pressure.

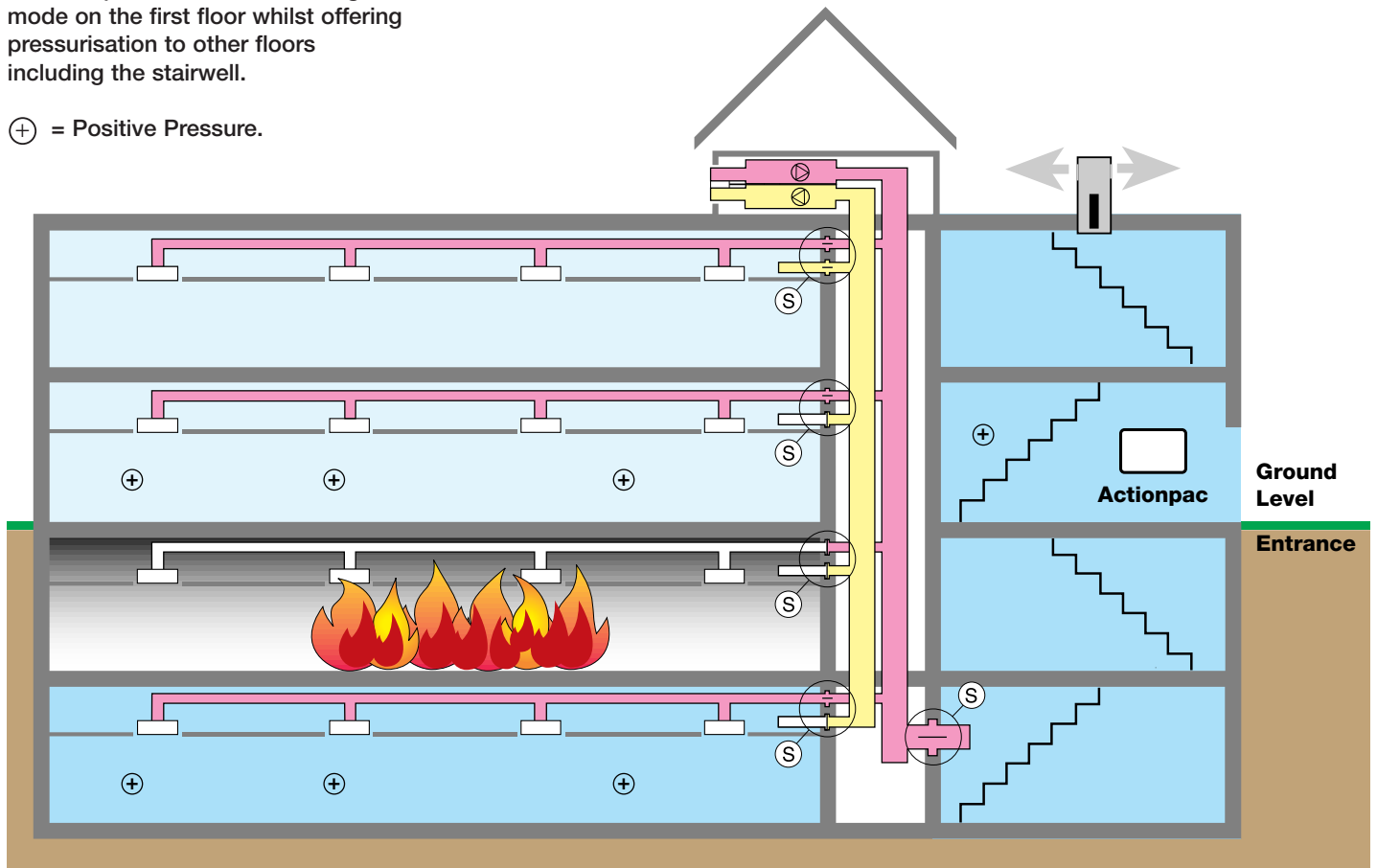

# Specification



Panel PC

### Control Panel

The Actionair Actionpac LNS3 System consists of a Panel PC, UPS and pre-loaded software. The system communicates with damper interfaces to provide intelligent control and monitoring of motorised dampers and monitoring of manual fire dampers. The data network cabling enables substantial reduction in costs when compared with conventional systems. Digital inputs and outputs (DI804) can be accommodated on the network cable or located within the panel enclosure.

The Panel PC is supplied with Actionair Actionpac LNS3 software and operates on an embedded platform, which is extremely user friendly. The server architecture delivers new benefits such as reduced commissioning time, ease of configuration, simplified operation, future system growth, full diagnostics for system and device integration along with optional automatic scheduled damper testing.

### Actionpac LNS3, as supplied by Actionair.

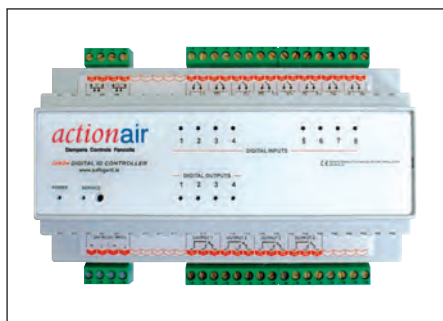

### Digital Input / Output Device (DI804)

This device accepts eight volt free contact inputs into the Actionpac LNS3 System. Typical inputs would be from fire alarm panels, fireman's override switches, manual call points and smoke detectors.

This device also provides four relay outputs to be driven from the Actionpac LNS3 System. Typical outputs would be to fans and BMS systems.

Complex strategy (cause and effect) lists

can be driven from this input / output device which is located within the Panel PC enclosure.

Other I/O devices are available.

### Mimic Panels

Bespoke LED mimic panels are available to clients' specification.

### Firefighter's Override Panels (FOP)

Bespoke key switch or push button firefighter's override panels are available to clients' specification.



can drive cause and effect schedules.

### Smoke Fire Damper Interface (SFDI)

This device, which is a registered Lon Mark® FSDAC product, is required for each smoke fire damper used with the Actionpac LNS3 System .

The SFDI controls and monitors motorised smoke/fire dampers. The device ensures correct operation and status of the damper and provides an alarm at the PC Panel in the event of local power supply failure.

the other via spring return. Actuator can alternatively be modulated via 2 – 10V signal from BMS.

### Smoke Damper Interface (SDI)

Energises actuator to drive open/drive closed damper.

### Fire Damper Interface (FDI)

Monitors damper position and provides facility for energising an electromagnet. Damper fail safes closed via its spring mechanism and must be manually reset.

### Damper Interfaces

The damper interfaces, except for the 3 PSFDI, accept local auxiliary inputs (normally duct smoke detectors) which

### 3 Position Smoke Fire Damper Interface (3PSFDI)

Actuator can be set to a balanced position or driven one way and fail safes

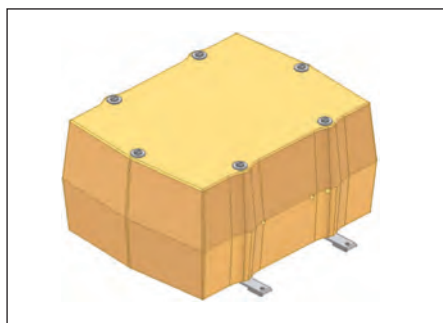

### Hot Damper Interface (HDI)

The HDI with a unique thermal enclosure (HDI) offers protection of the various interfaces to control and monitor

Hot/Shield dampers up to 300°C for 1 hour.

The HDI enclosure consists of two separate materials, enabling the HDI to function at the extreme temperature specified. The outer casing has endothermic properties that significantly slow down the internal temperature rise in a high temperature emergency condition. The inner casing is a special thermal insulating material.

The unit has been tested and independently witnessed by BRE (Ref Test No. 221067A).

### Sectional View of HDI Enclosure

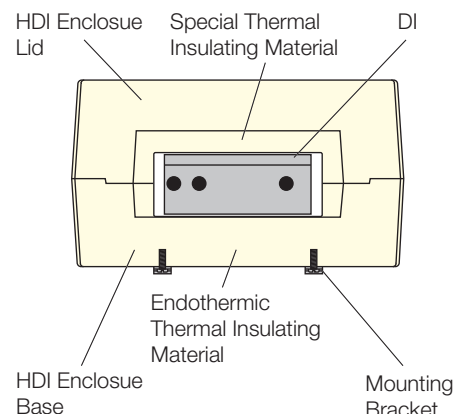

# SFDI Wiring Detail

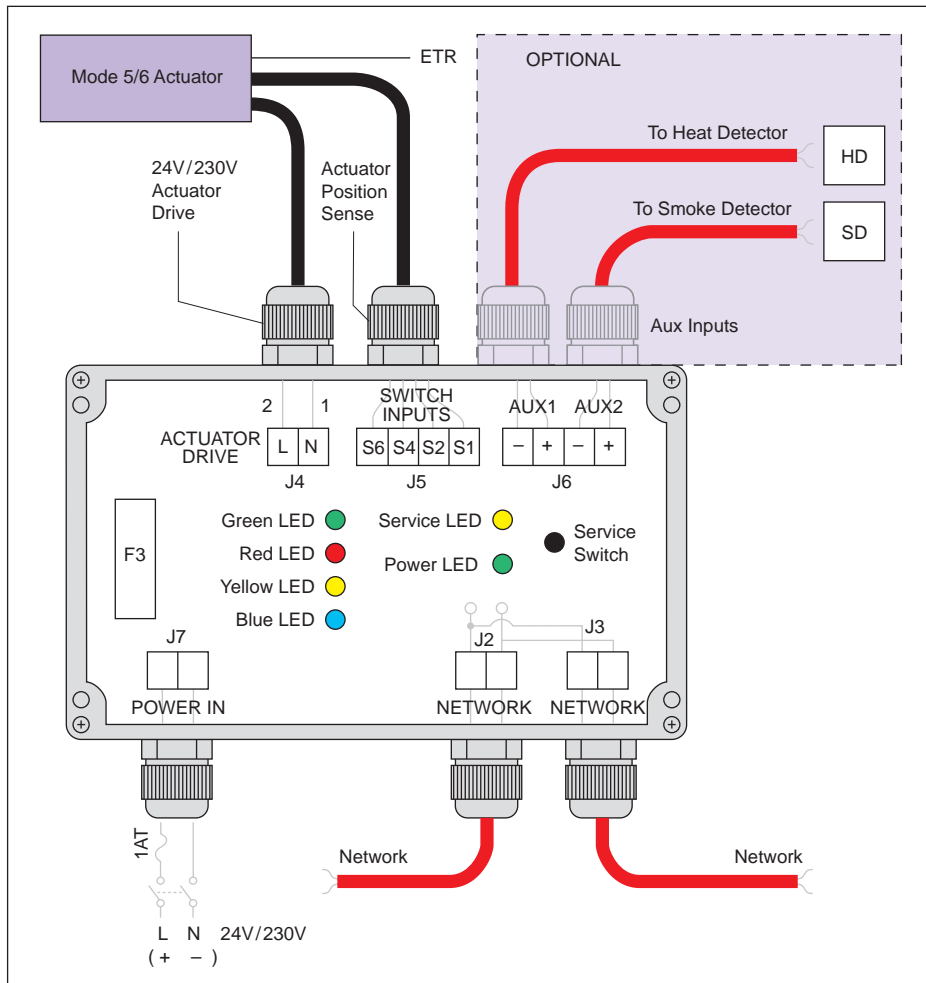

### Control Options

System will control and monitor most motorised dampers and offers monitoring of any dampers that are manually reset.

### Typical Operation

- Power On – Damper resets
- Power Off – Spring release
- Release Time • 20 secs.
- Reset Time • 60 secs.

### 24V AC or DC

Connect 24V via a safety isolating transformer.

### 230V AC 50 / 60Hz

1 amp fused spur to be provided. EN wiring regulations to be observed.

### Power Consumption

24V AC or DC  
230V AC  
Maximum power consumption for combined SFDI plus 24V or 230V actuator is <17W.

### LED Behaviour

Function	Green ●	Red ●	Yellow ●	Blue ●	Service (Yellow) ●	Power (Green) ●
Open	On	Off				On
Closed	Off	On				On
Travelling	Flashing	Flashing				On
Fault			Flashing			On
Ping (Communicating)				One-shot		On
Offline	On	On	On	On		On
Wink					Flashes for 5 secs	On

# Cable Specifications

Cable Type	Fire rated	Max length between devices	Max length per network channel	Conductor size
Belden 8471 NH		400m	500m	1.3mm <sup>2</sup>
Prysmian (Pirelli) FP 200 Gold	●	400m	500m	1.5mm <sup>2</sup>
Prysmian (Pirelli) FP Plus	●	400m	500m	1.5mm <sup>2</sup>
Firetuf FT120	●	400m	500m	1.5mm <sup>2</sup>

These cable specifications are fundamental to the stable and reliable operation of your smoke/fire control and monitoring system.

**Failure to adhere to these specifications will result in unstable and unreliable network communications and will void all warranties.**

- Maximum number of devices\* per network channel is 64. If >64 and / or >500m a network extender is required.
- If wired as a loop, the network is polarity sensitive. In all other instances, the network is polarity insensitive.
- Networked devices are wired in a simple 'daisy chain', (in and out). No cable stubs permitted.

\* A device is one of the following:- Damper Interface, Hot Damper Interface, NDI404, Network Extender or a Panel Router.

N.B. A multiple damper requires one Damper Interface or Hot Damper Interface per damper/section

# Typical Network Schematic

General Schematic of Actionpac LNS3 Damper Control System

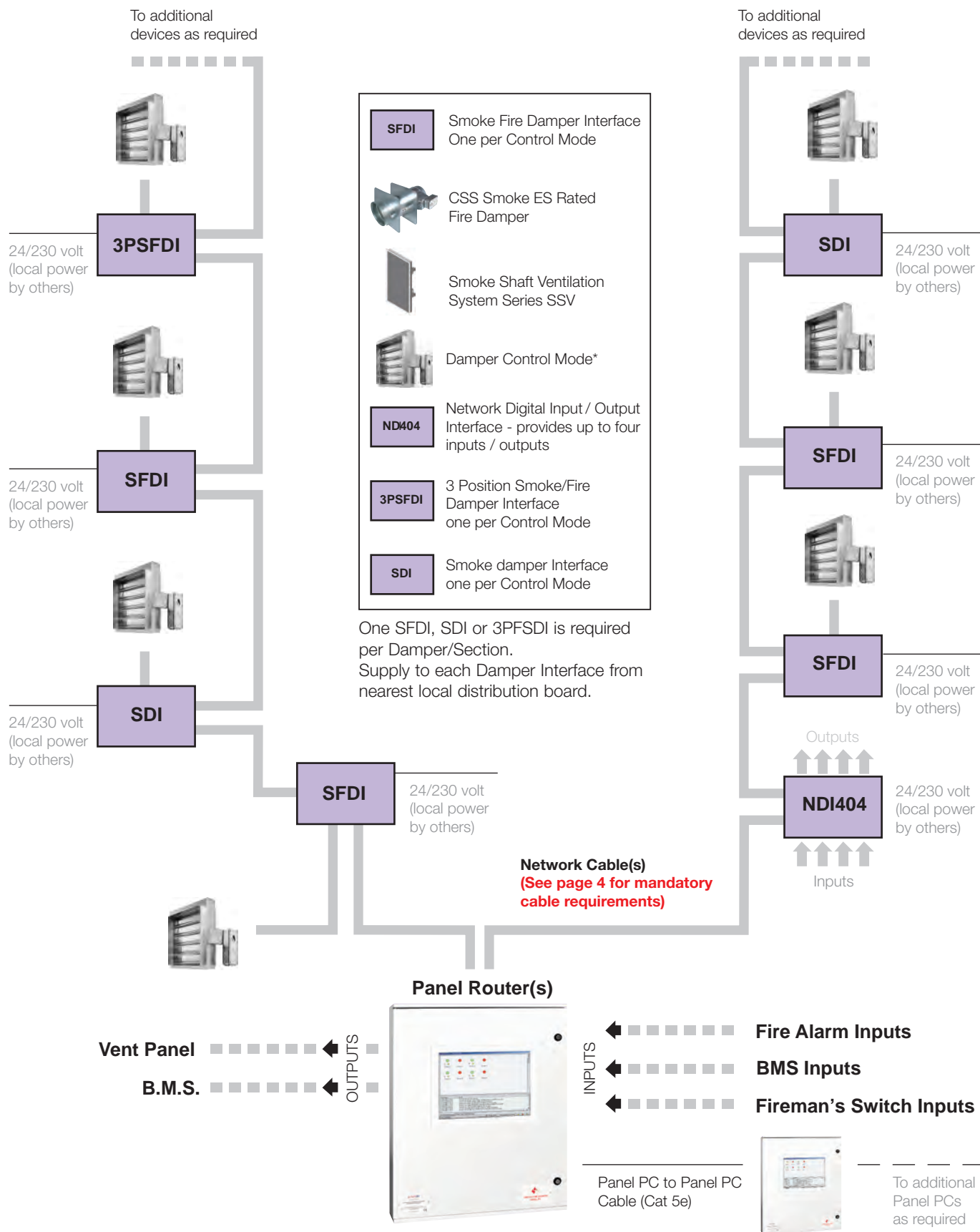

## Benefits

- Actionair experience and know-how in the damper market
- Actionair Smoke/Fire Dampers LPCB approved
- Allows for phased commissioning and future expansion
- Backward compatible
- CE marked, EMC and LVD compliant
- Customer testimonials available
- Hundreds of prestigious reference sites
- Powerful and very flexible functionality accommodates any last minute changes to strategy, zones, damper quantities, references and descriptions etc and enables standardisation of software (no bespoke site specific versions required)
- Off site system witnessing can be arranged
- Open and interoperable protocol (LonWorks®) allows possible support by others and future proof lifecycle preventative maintenance costs
- Optional networking of panels to a central control and monitoring panel - up to 32 networked panels to meet practically any building's damper requirements
- Optional automatic scheduled damper testing, including omit option for critical dampers
- Optional remote access via internet
- System designed to cater for environmental occupancy (energy saving) as well as the building's smoke/fire strategy

## System Commissioning

Actionair offers a comprehensive after sales service to include pre-commissioning checks and a complete commissioning service for all our products. Our Standard Commissioning service includes the following:-

- Attendance at all necessary induction courses and site familiarisation.
- Final connections of inputs to system from fire alarms, override switches, BMS etc.
- Final connections of each damper interface unit, electrical contractor to have ensured all necessary cables are entered into enclosure glands.
- Establishing communication to each damper interface unit.
- Viewing of damper blade movement to check operation.
- Configuring of the relevant cause and effect.
- Demonstration / witnessing of 10% of dampers installed. Full witnessing available by special request.
- Client Training on the system.

### Customer Service

Actionair provides quality products backed by a dedicated team committed to providing the very best in customer service.

We also offer experienced technical backup, comprehensive sales and administrative customer support, product commissioning and maintenance service.

## Enclosure Specifications

Standard enclosure sizes and weights are dependent on the number of data networks and DI804's required.

Enclosure Size (mm) W x H x D	Max Load (Watts)
600 x 600 x 210	500
800 x 800 x 210	500
800 x 1000 x 300	500
800 x 1200 x 300	500
<b>Colour</b>	RAL 7035
<b>Hinged</b>	Left
<b>Power cables</b>	Bottom of right hand side
<b>Network cables</b>	Top entry
<b>I/O cables</b>	Top entry
<b>Protection</b>	IP 20 (230 Volt terminals shrouded)
<b>Max ambient temperature</b>	30 °C (Panel must be in a ventilated environment)

## Other Addressable Panel Options



### Actionpac LNS 60/120

The Actionair Actionpac LNS 60/120 System consists of a Panel PC, UPS and pre-loaded software. The system communicates with damper interfaces to provide intelligent control and monitoring of motorised dampers and monitoring of manual fire dampers. The data network cabling enables substantial reduction in costs when compared with conventional systems. The digital inputs and output device (DI804) is accommodated within the panel enclosure.

The Panel PC is supplied with Actionair Actionpac LNS 60/120 software and

operates on an embedded platform, which is extremely user friendly. The server architecture delivers new benefits such as reduced commissioning time, ease of configuration, simplified operation, full diagnostics for system and device integration along with optional automatic scheduled damper testing.

#### Note:

Actionpac LNS 60/120 is recommend when there are more than 30 smoke/fire dampers to be controlled and monitored. Refer to Actionpac LNS 60/120 brochure for full details.

## Actionpac Electro Mechanical Smoke and Fire Damper Hard Wired Control Panels



### EMS – Standard

Control and monitoring system.

Actionpac Electro Mechanical Smoke and fire damper control system.

Automatic damper operation utilising relay logic and LED indication of damper status.

Standard Modular Construction.

LED indication of damper status.

Mains isolator.

Test/Normal/Override Keyswitch.

Lamp test facility.

2 Versions (Mode 5 and Mode 6), available in 3 sizes, from Stock.

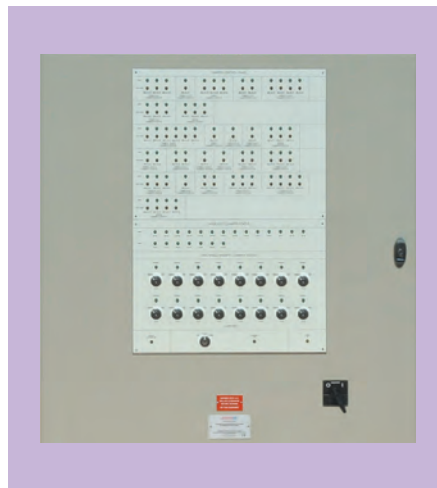

### EMB – Bespoke

Control and monitoring system.

Actionpac Electro Mechanical Smoke and fire damper control system.

Automatic damper operation utilising relay logic and LED indication of damper status.

#### Features

Customised central Control Panel.

Individual, or collectively controlled and continually monitored.

Wall mounted enclosure to IP55.

Custom Engraved Traffolyte fascia.

LED indication of damper status.

Zonal inputs.

Door interlocking isolator.

Miniature circuit breaker protection.

#### Options

Lockable glazed door.

Special paint finish to BS standard colour reference numbers.

Flush mounting flanges.

Latching push buttons.

Fireman's override key switches.

Test Switch.

Lamp Test.

Audible alarm with mute facility.

B.M.S. common fault relay interface.

B.M.S. output.

Delay timers.

Battery backup.

#### Specialist Panels available

Fan Control Panel.

Fireman's control panel.

Mimic (Repeater) Panel

Fire damper monitor (Indication) panel.

**Note:** Actionpac EMS (Standard) or Actionpac EMB (Bespoke) Systems are recommended for areas where there are less than 30 dampers.

**Ruskin Air Management Limited  
is a ISO 9001 and 14001 registered  
company.**

The statements made in this brochure or by our representatives in consequence of any enquiries arising out of this document are given for information purposes only. They are not intended to have any legal effect and the company is not to be regarded as bound thereby. The company will only accept obligations which are expressly negotiated for and agreed and incorporated into a written agreement made with its customers.

Due to a policy of continuous product development the specification and details contained herein are subject to alteration without prior notice.

**Comprehensive and detailed information  
is available for all Actionair products.  
Visit our website at [www.actionair.co.uk](http://www.actionair.co.uk)**

## **Ruskin Air Management Limited**



South Street, Whitstable, Kent  
CT5 3DU England.  
Tel: 01227 276100  
Fax: 01227 264262  
Email: [sales@actionair.co.uk](mailto:sales@actionair.co.uk)  
Website: [www.actionair.co.uk](http://www.actionair.co.uk)

***actionair***  
Dampers Controls Fancoils