



# Actionair

## M5-3P-CMS

Mode 5 Three Position Control and Monitoring Station

### Application

To further enhance the positioning capabilities offered by the M5-3P control mode

### Features

Set the positioning signal for the M5-3P locally using the TRIM feature

Outputs are available to give volt free contacts indicating that the unit is at SET POINT, at full RESET, or full RELEASE

Alarm input available to cause unit to RELEASE

Alarm input available to cause unit to RESET (this is overridden by the RELEASE alarm input)

Lamps provided on the outside of the unit showing position – SET POINT, RESET or RELEASED

Travelling lamps indicate that the unit is trying to move and in which direction.

Swap from local control to 2-10Vdc external by changing over a "jumper" inside the unit

Push button test switches are provided to allow local testing of the damper

One unit required per damper

All the above save the expense of complicated wiring and logic on site

### Specification

An Actionair M5-3P-CMS to be provided with each Actionair M5-3P to enable local set point control, local lit status and volt-free outputs indicating SET POINT, RESET and RELEASE damper states, local damper trying to move indication, local test switches and external input capability to ALARM input full RESET and RELEASE

### Installation

The M5-3P control mode should be connected to the labelled terminals A1 to A10. All the cables must be connected. Only competent persons should undertake this.

The unit must be given a 24V(±10%) ac or dc local supply. This must be capable of delivering 11VA. This supply will run both the unit and the actuator. This should be connected to terminals A12 & A11. The unit must be earthed to either terminal E1 or E2. The remaining terminals are optional.

Terminals C1 & C2 must be linked out to allow the unit to function. The supplied link may be removed and replaced by a remote N/C volt free contact. This is the release alarm and opening this contact will cause the damper to spring return to RELEASE. This takes priority over all other inputs.

Terminals B3 & B4 give the option of RESET override. A remote N/O volt free contact will allow normal operation, but closing the contact will cause the damper to move to the fully RESET position.

Terminals B5 & B6 give volt free indication of the damper being at the RELEASE position.

Terminals B7 & B8 give volt free indication of the damper being at the RESET position.

Terminals B9 & B10 give volt free indication of the damper being at the SET POINT position.

Terminals B1 & B2 allow remote input of a clean 2-10Vdc positioning voltage. For this function to work, the jumper on the pcb within the unit must be set to external.

Terminal B11 & B12 allow the 2-10Vdc position monitoring voltage to be monitored externally.

### Operation

Supplying power to the unit will move the associated damper to the SET POINT. This is set by either using the TRIM potentiometer (10 turn) on the front of the CMS unit (see HINT), or by supplying the unit with an external 2-10Vdc signal.

Two push buttons are provided for testing. Each button should be held until the damper reaches the desired position as indicated by the relevant lamp lighting up. Pressing both buttons at the same time will cause the unit to travel towards the RELEASE position.

**HINT:** The SET POINT may be "chased" by using the test buttons to set an airflow, releasing them, and then adjusting the TRIM potentiometer to turn on the SET POINT lamp. The buttons must be released else the lamp will not light.

When the damper reaches the SET POINT the green lamp will light. There are two additional lamps, one red to indicate fully RELEASED, and one yellow to indicate fully RESET.

Two additional small red lamps indicate that the unit is trying to move towards RESET or RELEASED. Either of these will remain lit until the SET POINT is reached. (In the case of override, or testing, these will light in the opposite direction to which the unit is actually moving and will remain lit in this way until the unit returns to set point.

The damper will only Spring Return to the RELEASE position if the power is lost, contact between terminals C1 and C2 is lost or the ETR trips.

Test that the unit functions as expected.

### If unit does not function as expected

Check that there is the correct supply to the unit.

Check that the M5-3P control mode is connected correctly and any ETR fixed to the duct correctly.

Check the continuity of the ETR thermal probe.

Check that there is a closed contact between terminals C1 & C2.

Check the jumper setting – i.e. internal or external to ensure that either local TRIM is working or an external voltage is expected.

If the manual override (allen key winder) has been used on the M5-3P control mode, it may go through a start up routine to find its end positions, before finally settling at the SET POINT.

**Important Note:** This Mode 5-3P control mode is for **3 position setting**, i.e. RESET, RELEASED & one SET POINT. It is **not for modulating** on a continuous basis. The third position could be changed externally once or twice on a daily basis for night set back or boost, but should be limited to this, as otherwise wear may result causing the damper unit to be unable to fulfil its life safety function at some point in the future. VAV type systems should still be addressed with a control damper in line

# M5-3P-CMS Terminal Information

## TERMINALS B

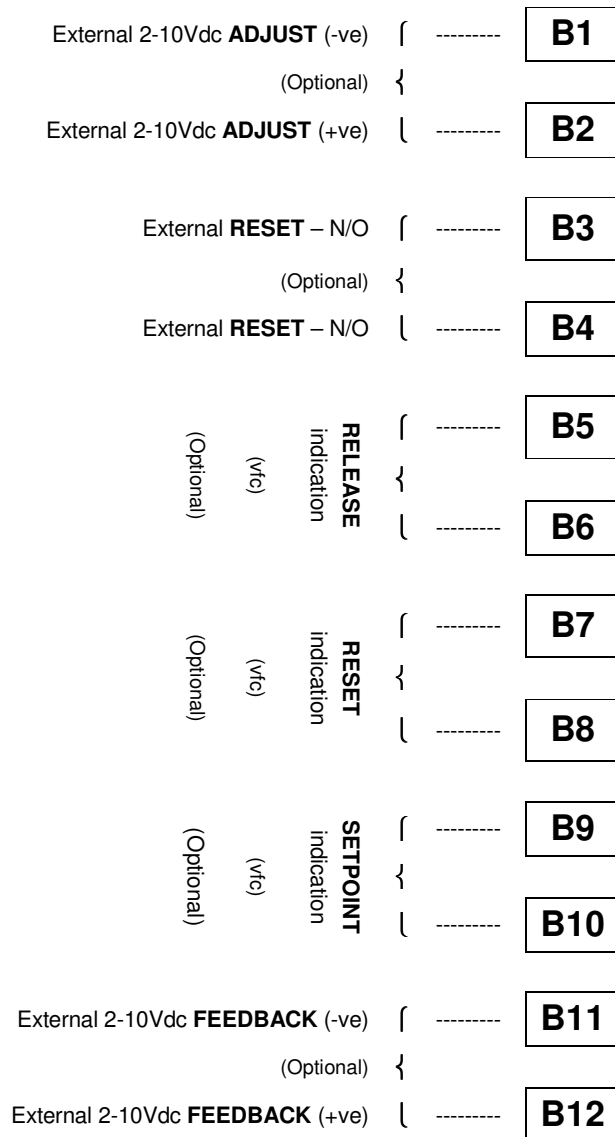

## TERMINALS C

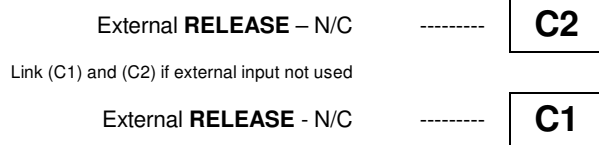

## 3 PIN JUMPER

Internal Position TRIM  
External Position Input



## TERMINALS A

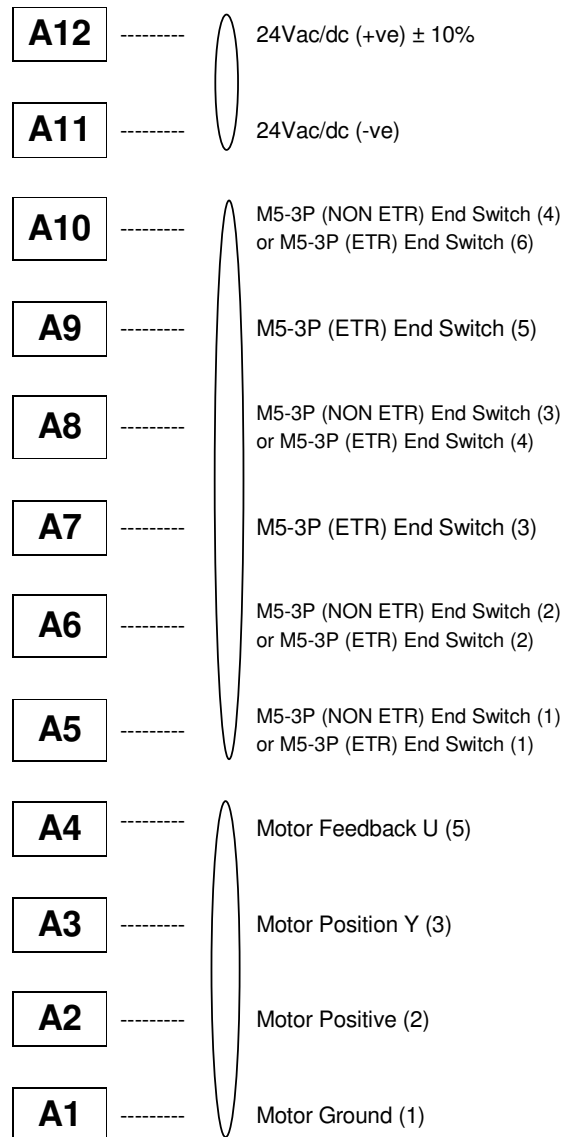

## TERMINALS E

