

THE SYSTEM

The Actionpac 60 & 120 system is a flexible damper control panel that runs on a 15inch industrial PC utilising solid state drive technology for optimum reliability.

The PC is protected by a UPS to provide controlled shut down in the event of a power failure.

The Actionpac 60 & 120 software manages the control and monitoring of Smoke/Shield dampers by utilising a LonWorks® data base. All devices that are on the system receive a “heartbeat” to ensure reliable communications. A system back up of the site configuration is taken upon completion of commissioning. A system image of the site configuration is provided as part of the handover documentation.

DAMPER INTERFACE

The Actionpac 60 & 120 controls and monitors Smoke/Shield dampers via a Smoke/Fire Damper Interface.

Smoke Fire Damper Interface (SFDI) Energises actuator to drive and fail safes via spring return.

DI804

A DI804 is an input/output device, which accepts/provides inputs & outputs to/from the system.

1 off DI804 can be accommodated on either system providing 8 off hardwired inputs and 4 off relay outputs. Also, each damper interface (DI) has the facility to accept up to two auxiliary inputs (voltage free contacts normally from duct smoke detectors) which are treated as virtual inputs to a DI804. A maximum of up to 8 off virtual inputs can be accommodated in total.

The DI804 accepts up to eight hardwired inputs (voltage free contacts) and up to eight virtual inputs from damper interfaces (DI's). Normally closed or normally open are selectable in software. For the hardwire inputs 2 x 1mm² cable up to 50m is acceptable.

The DI804 provides up to four single pole relays rated at 3A 230V AC or 3A at 30V DC (normally closed or normally open are selectable in software)

The DI804 device is required to allow the programming of the building strategy (cause & effect).

*action*air

Dampers Controls Fancoils

Ruskin Air Management Limited

www.ruskinuk.co.uk

Priority Levels

There are **3** priority levels on inputs

- P1** Highest “Firefighter” A firefighter input runs its associated actions and then returns the dampers back to their normal states when deactivated.
- P2** Medium “Fire Alarm” A fire alarm input runs its associated actions; it only returns the dampers back to their normal states when all fire alarm inputs are deactivated. There is an optional lock out feature at this level which, when activated, runs the associated actions with the first fire alarm input only.
- P3** Lowest “Environmental” An environmental input runs the associated actions and then returns the dampers back to their normal states when deactivated.

If P1 inputs are active P2 & P3 are ignored, likewise if P2 inputs are active then P3 are ignored.

NETWORK CABLES

Damper interfaces are wired back to the PC panel on Actionair approved network cable(s) to communicate with the panel. For Actionpac 60 up to 2 off networks are permissible and these networks communicate with the panel via a 2 way panel router. For Actionpac 120 up to 4 off networks are permissible and these networks communicate with the panel via a 4 way panel router.

For Actionpac 60, if the network cable is greater than 500m in length, then a Network Extender (NE) must be fitted. For Actionpac 120, if more than 64 off SFDI's and/or a network cable of more 500m in length, then a Network Extender (NE) must be fitted.

Approved cables:	Belden 8471 NH	(2 x 1.3mm ²) – non fire rated
	Pirelli FP200 Gold	(2 x 1.5mm ²) – fire rated
	Pirelli FP Plus	(2 x 1.5mm ²) – enhanced fire rated
	Firetuf	(2 x 1.5mm ²) – fire rated
	Firetuf Plus	(2 x 1.5mm ²) – enhanced fire rated

SYSTEM SIZE

Actionpac 60 - maximum 60 off Smoke/Shields. Actionpac 120 – maximum 120 off Smoke/Shields. Either system, maximum 64 off groups (zones or whatever client terminology is required, max 70 characters). Maximum 32 off SFDI's per group.

PANEL SIZES

One panel size for either system (H x W x D in mm):

600 x 600 x 210

PC

The PC chosen to host the Safeguard 60/120 software utilises a compact flash drive and provides touch screen keyboard/mouse as standard. The PC must to be placed in a ventilated environment and the ambient room temperature must be maintained below 30°C.

The PC is fully embedded and has no moving parts and the graphical user interface (GUI) is extremely user friendly.

The Safeguard 60/120 application is in two modules; the system builder and the system engine. The system builder is the commissioning tool and the system engine provides the GUI for the client upon system handover.

The Safeguard 60/120 application utilises a LonWorks® Network Services 3 database.

Site back ups are kept of all sites and stored on a secure main server and a system image of the site configuration is provided as part of the handover documentation

.

UPS

A UPS provides surge protection and battery back up for the PC and for the panel DI8O4 & panel router.

SMOKE FIRE DAMPER INTERFACE (SFDI)

The SFDI is available in a 24V ac/dc or 230V ac version. Normally, there is one SFDI per damper, however, for multiple dampers the end switches can be wired in series and therefore be controlled and monitored by one SFDI. The requirements for controlling and monitoring multiple damper arrangements should be discussed with Actionair technical sales.

Smoke Fire Damper interfaces require a local power supply (see separate SFDI user guide).

When energised by the Actionpac 60 or 120 software, the relay is closed providing power for driving a smoke fire damper actuator. When denergised the relay is opened, thereby cutting power. The end switches (volt free contacts) which represent the open and closed position of the damper are wired to the SFDI and monitored by a 12V (19mA) sensing supply.

Each SFDI has the facility to accept up to two auxiliary inputs (volt free contacts normally from duct smoke detectors) which are treated as virtual inputs to a DI8O4 – input/output module to drive cause & effect schedules.

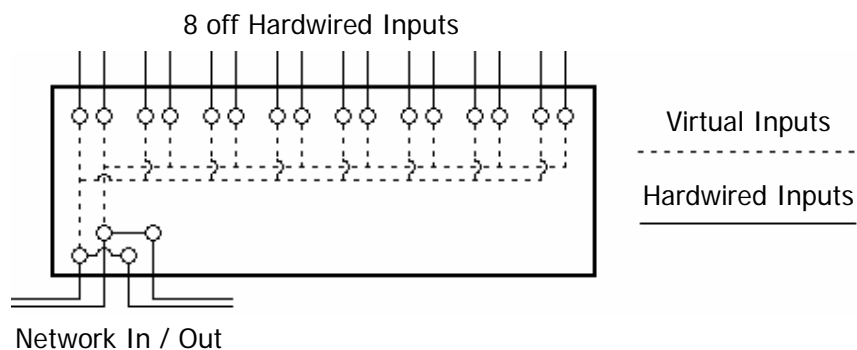

Any fault in an SFDI will cause it to find its failsafe position before attempting to move to its final position.

Scheduled auto testing of all dampers individually is optional and achieved by an input into a DI8O4 at the environmental level P3. Critical dampers that must not cycle can be chosen and ignored during a test.

BMS

The BMS can communicate with the Actionpac 60 & 120 software in various ways.

Inputs from the BMS to control dampers for occupancy and/or energy saving are via volt free contacts. The Actionpac 60 & 120 software accepts these contacts into a DI8O4 – input/output module and they are classed as “Environmental inputs”. Environmental inputs have the lowest priority (P3) as they are for general HVAC requirements.

Outputs to the BMS are normally via relays from a DI8O4 input/output module. Groups of dampers and/or system faults can be monitored in various ways to either make or break a relay contact.

If required, the monitoring of damper status by the BMS can also be achieved by connecting onto the Actionpac network cable. In order to do this, the BMS must use a LonWorks Network Services 3 database, however, it can only monitor and no control of the dampers will be possible. Should the BMS not be using a LonWorks Network Services 3 database, then it can also monitor damper status via an RS232C serial connection. Actionpac 60 & 120 software provides an ASCII string – no protocol conversion available.

An environmental input runs the associated actions and then returns the dampers back to their normal states when deactivated.

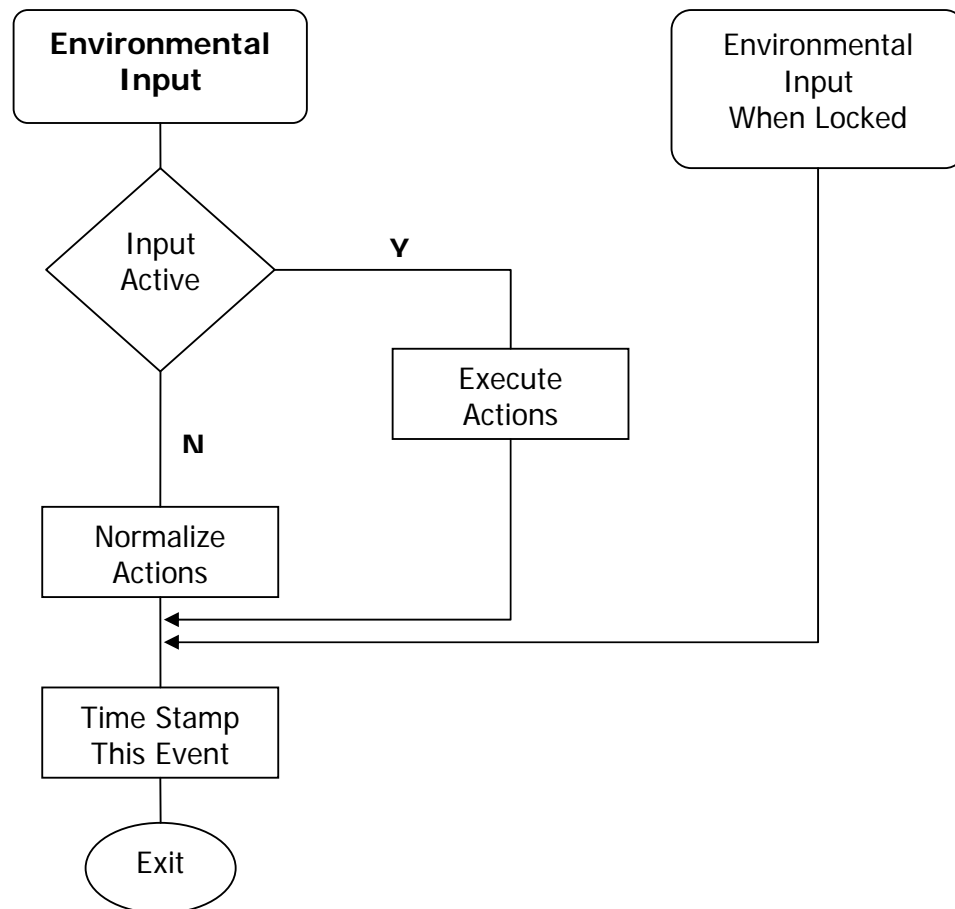

Fire Alarm

Inputs from the fire alarm to control dampers in the event of a fire are via volt free contacts. These inputs are programmed according to the building strategy (cause & effect schedule). The Actionpac 60 & 120 software accepts these inputs into a DI8O4 – input/output module and they are classed as “Fire Alarm inputs”. Fire alarm inputs (P2) have a higher priority than environmental inputs as they are for smoke and fire control.

A fire alarm input runs its associated actions; it only returns the dampers back to their normal states when all fire alarm inputs are deactivated. There is an optional lock out feature at this level which, when activated, runs the associated actions with the first fire alarm input only.

A fast fire alarm input for gas suppression systems is available and provides an instantaneous response to an input.

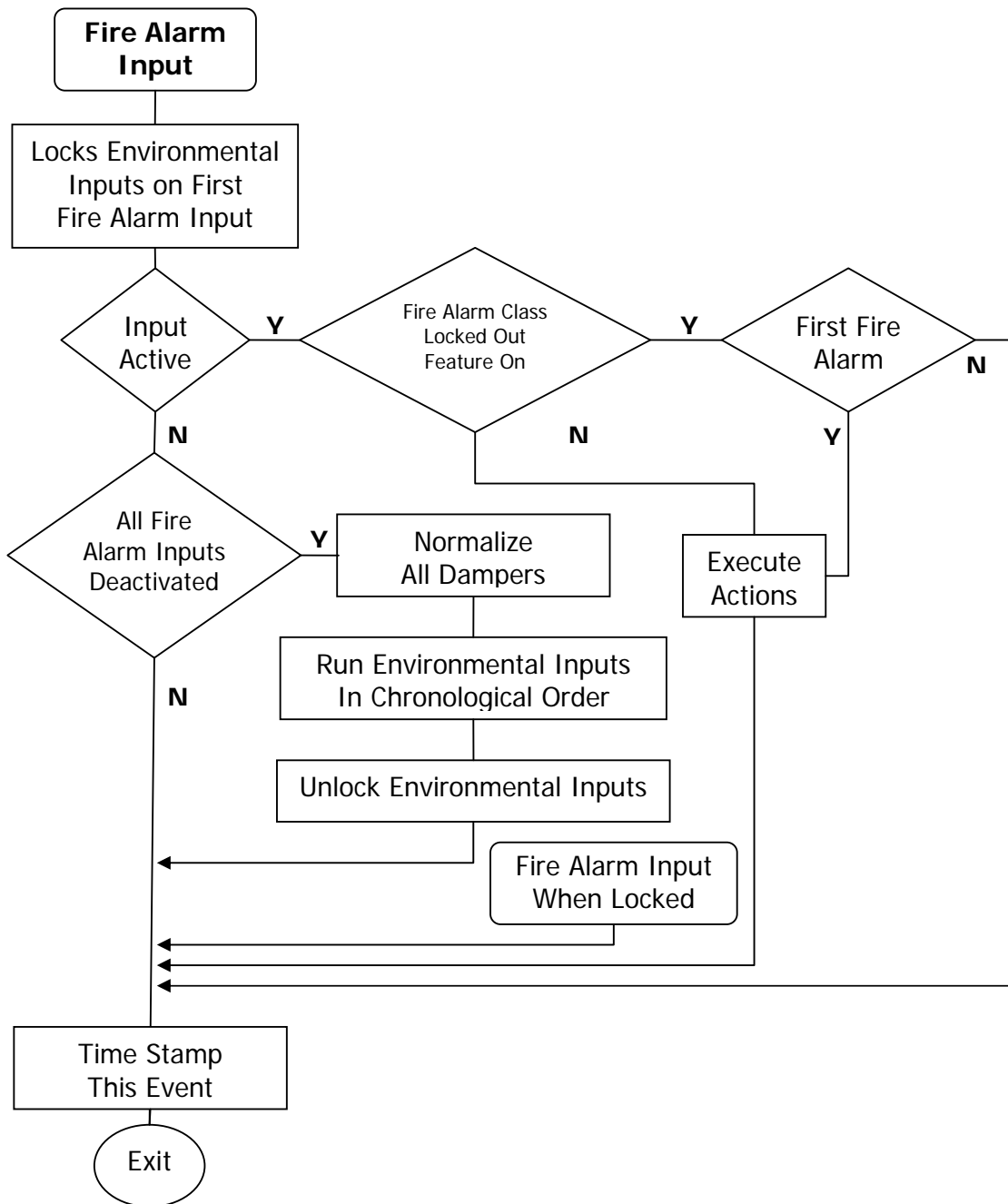

Firefighter

Inputs from the firefighter to control dampers in the event of a fire are via volt free contacts. These inputs are programmed according to the building strategy (cause & effect schedule). The Actionpac 60 & 120 software accepts these inputs into a DI8O4 – input/output module and they are classed as “Firefighter inputs”. Firefighter inputs have a higher priority (P1) than both fire alarm and environmental inputs as they are for emergency smoke and fire control under the manual control of the firefighter.

Normally, the firefighter inputs are via keyswitches that are built onto the front of the Actionpac panel. A bespoke firefighter's override panel can be manufactured if this is not an option.

A firefighter input runs its associated actions and then returns the dampers back to their normal states when deactivated. The system will automatically return to fire alarm control when all firefighter inputs are deactivated.

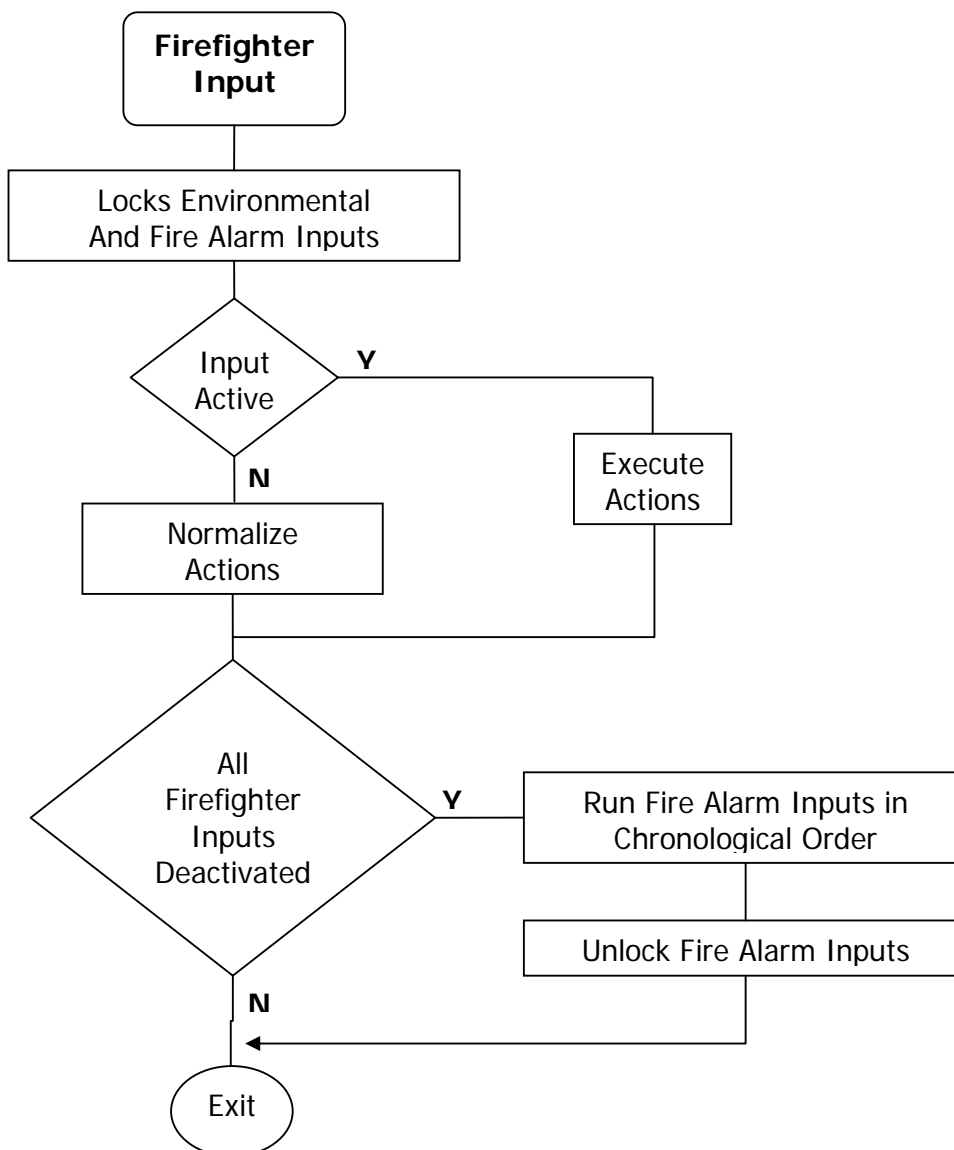

DI804

The DI804's resides in the Safeguard panel and is referred to as "Panel DI804", however, sometimes it is necessary for them to reside on the network, in which case they are referred to as "Network DI404". NDI404's accept up to four inputs and provide up to four off relay outputs.

NDI404's are available in 230Vac (11VA) or 24Vac/dc (9VA). Enclosure size 400 x 200 x 132 (L x W x D in mm) including glands, which are prefitted.

The following input actions are programmable and up to 8 actions per input (hard wired or virtual) is allowed:

Open, Close, Test, Normalize or Failsafe a Group or Groups

Execute, Hold or Release a Strategy

Start/Resume, Stop or Suspend a Damper Test

Please note: Test can only be undertaken at the Environmental Input level.

The following output events are programmable and up to 8 events per output are allowed. The output can be activated by any or all of the event conditions being met or by Boolean expression.

Group, Groups, Set or Super Set on the following:

Open, Not Open, Closed, Not Closed, Normal, Not Normal, Failsafe, Not Failsafe, Fault and Not Fault

On Firefighter Input, On Fire Alarm input, On Environmental Input

On Threaded Firefighter Input, On Threaded Fire Alarm input, On Threaded Environmental Input

On Damper Test Running, On Damper Test Suspended, On Not Damper Test Suspended

On Input Set Active, On Input Set Match

On Set Traveling, On Service Due, On DIO Fault, On Not Input, On Input (Not Locked Out)

Please note: A set can be one or a number of dampers across groups

A superset is all dampers on the system

If a DIO cannot communicate with the system for whatever reason, the dampers associated with its input actions are placed at their failsafe positions (or not as programmed by the commissioning engineer) as a precautionary measure. This occurs irrespective of the conditions of the P1, P2 and P3 inputs. On its recovery, its inputs actions will be executed according to the input rules. If no inputs are active on recovery then an 'All Groups Normal' action will be issued.

Network Extender

For Actionpac 60, if the network cable is greater than 500m in length, then a Network Extender (NE) must be fitted. For Actionpac 120, if more than 64 SFDI's and/or a network cable of more 500m in length, then a Network Extender (NE) must be fitted.

NE's require a local power supply and are available in 230Vac (3VA) or 24Vac/dc (2VA) versions. Enclosure size 400 x 200 x 132 (L x W x D in mm) including glands, which are prefitted.

Approved Cables

Approved cables:	Belden 8471 NH	(2 x 1.3mm ²) – non fire rated
	Pirelli FP200 Gold	(2 x 1.5mm ²) – fire rated
	Pirelli FP Plus	(2 x 1.5mm ²) – enhanced fire rated
	Firetuf	(2 x 1.5mm ²) – fire rated
	Firetuf Plus	(2 x 1.5mm ²) – enhanced fire rated

There are no alternatives or equivalents acceptable. Use of any other cables will void all warranties and they will have to be replaced to maintain reliable and safe operation of the system.

Normally, SFDI's are wired radially ("daisy chained") from device to device. The network cable leaves the Actionpac panel and does not come back.

We always recommend radial wiring as the most cost effective and simplest installation. In the very unlikely event of a cable break, the devices after the break will failsafe. If this is considered to be an issue then a loop can be wired. In a loop, the cable leaves the Actionpac panel and "daisy chains" around each device and then returns to the panel from the last device. Radial networks are polarity insensitive and loops are polarity sensitive.

Standard network rules apply:

- *Cables should not be run alongside any high voltage and/or high frequency sources.*
- *Should cables need to be run outside a building, they must be installed underground as they are susceptible to lightning.*
- *Cables must not be mixed on an individual network as they have very different electrical characteristics and would render the system unreliable.*

Extending a radial network

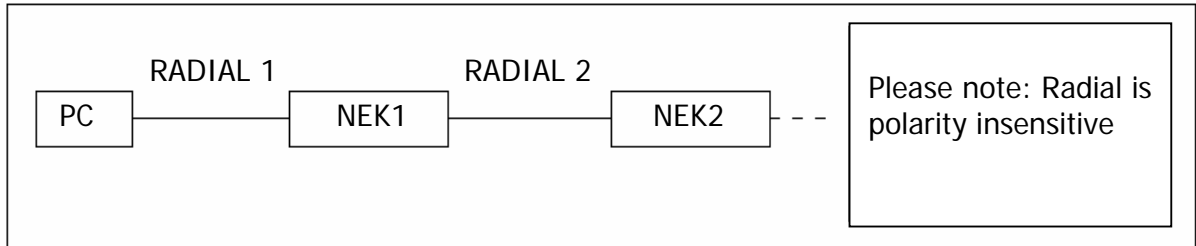

Extending a loop network

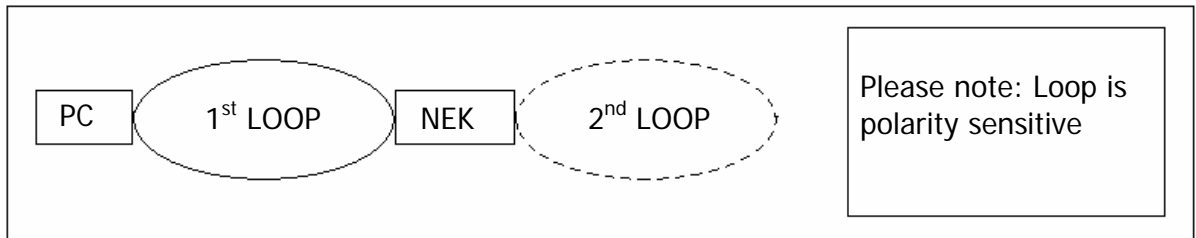

Panel

See generic drawings attached

Mimic panels

These panels are manufactured to order and provide status indication of dampers via LED's. If a mimic panel is required, we recommend providing damper status by groups rather than individual status, as the individual status is available from the main Safeguard panel.

Another alternative is to use a mimic VDU which can be placed up to 250m away from the panel.

Firefighter override panels

These panels are manufactured to order and can be mechanical or via touch screen VDU's.

System Log

A full event log of all system activity is maintained, this includes all user activity, device errors/recoveries and inputs/outputs activated/deactivated.

User

Access is provided to the system by logging in via a keypad (CTRL + F10). At the bottom of the PC screen it states "System Locked" when it is locked and "System Unlocked" when it is unlocked. For security reasons, the user must remember to log off after completing their works. Should the user have intentionally changed the position of a damper or a number of dampers, these will be indicated by a yellow warning triangle at the bottom of the screen and a number, being the numbers of dampers actually changed from their normal operating position. See separate user guide for full details.

Should the user wish to undertake maintenance on a damper or a number of dampers, then each damper must be locally isolated from its power supply before doing so. Maintenance must only be undertaken by suitably qualified personnel. Safeguard maintenance contracts are available upon request.

The following options are available to the user:

- *Open, close, normalize or failsafe a damper, a group or all groups*
- *Toggle a damper Online/Offline for maintenance purposes*