

# actionair

Dampers Controls Fancoils

Ruskin Air Management Limited  
www.ruskinuk.co.uk



ALWAYS READ THIS DOCUMENT  
BEFORE INSTALLATION. PLEASE  
RETAIN FOR FUTURE REFERENCE.

This product forms part of a life safety system. Failure to correctly store, handle, install and maintain the product will directly put at risk the lives of the occupants and the fabric of the building.

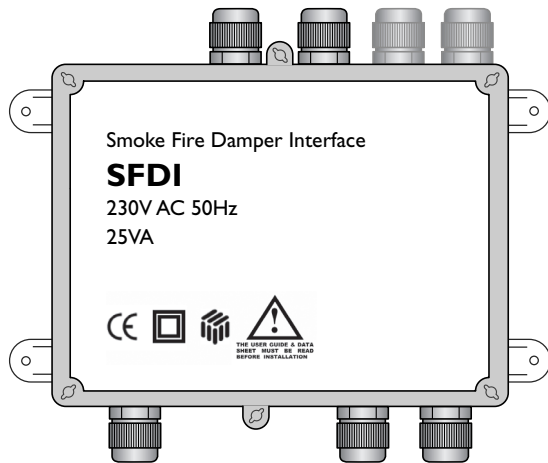

Installation Instructions and Datasheet

## Smoke Fire Damper Interface (230V)

The Safeguard Smoke Fire Damper Interface provides a complete LonWorks® communication device to control any failsafe spring-return smoke fire damper actuator that incorporates two auxiliary switches.

Two additional auxiliary inputs are provided for interfacing to local duct smoke detectors etc.

Safeguard developed the LonMark® Functional Profile (11001) for smoke fire dampers and this has been adopted worldwide.



ELECTROSTATIC SENSITIVE DEVICE

# actionair

Dampers Controls Fancoils

Ruskin Air Management Limited  
www.ruskinuk.co.uk

## Dimensions and Mounting

The compact and robust design of the SFDI enclosure allows the unit to be mounted to a duct, block wall or stud wall.

Ensure the SFDI is located close enough to the actuator it is controlling/monitoring. Normally, actuator leads are 1m in length. Also, ensure the SFDI is accessible for future maintenance purposes.

### Please note:

- Unused cable entries should be sealed with blind washers.
- Do not drill the enclosure as this will affect its IP rating.

## Mounting Diagram

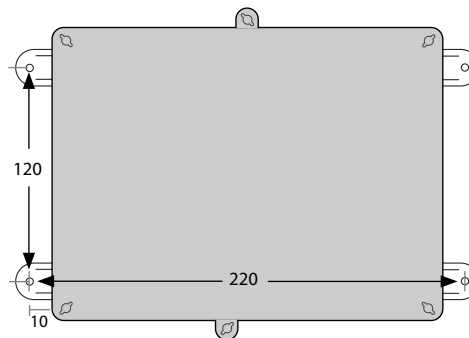
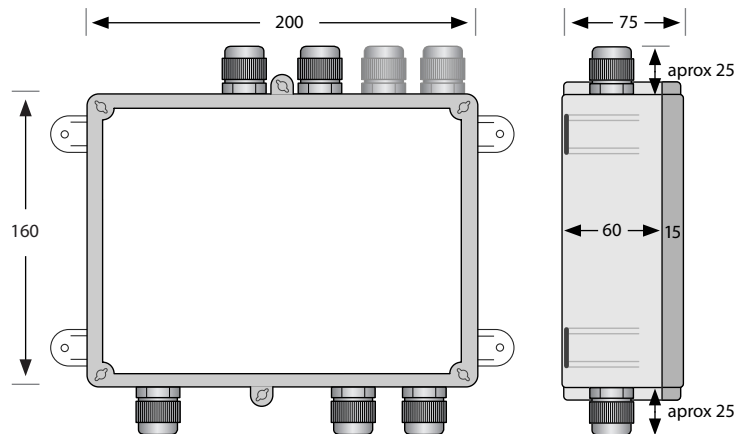

Four mounting holes  
Ø 6mm for mounting  
with suitable screws  
depending on whether  
mounting to a duct,  
block wall or stud wall.

Dimensions in mm.

# actionair

Dampers Controls Fancoils

Ruskin Air Management Limited  
www.ruskinuk.co.uk

## Preparation

- Only trained and qualified personnel should be allowed to install, replace or service this equipment. Installation should be in accordance with the relevant local safety standards.
- The connectors can accommodate cable diameters up to 2.5mm<sup>2</sup>. It is recommended that all wires be crimped to ease installation and replacement of the product.
- The mains wiring should comply with IEC 60227 or IEC 60245.
- A switch or circuit breaker should be included as part of the installation.
- The switch or circuit breaker should meet the relevant requirements of IEC 60947-1 and IEC 60947-3.
- The switch or circuit breaker should be in close proximity to the equipment and be within easy reach of the operator.
- The switch or circuit breaker should be marked as the disconnecting device for the equipment and should disconnect both poles of the supply

## Installation

1. Disconnect the local supply before commencing any work on the SFDI.
2. Wire the SFDI in accordance with the wiring diagram shown across. If actuator is to be located more than 5m from the SFDI then contact Safeguard Systems for technical assistance.
3. Please be aware that the switch and auxiliary inputs are not optically isolated. It is recommended that the optional detectors (smoke or heat) use failsafe open contacts to guarantee their detection in the event of a fault condition.

It is also recommended that the network cables are not run alongside any high voltage or high frequency sources. Also, network cables must not be mixed on an individual network as they have very different electrical characteristics and could render the system unreliable.

4. Once wiring is complete, apply power to the SFDI. The green power LED should illuminate to indicate the presence of power.
5. The SFDI is now ready to be configured using a standard LonWorks tool such as LonMaker or the Safeguard system.

## Wiring Diagram (SFDI in enclosure without lid fitted)

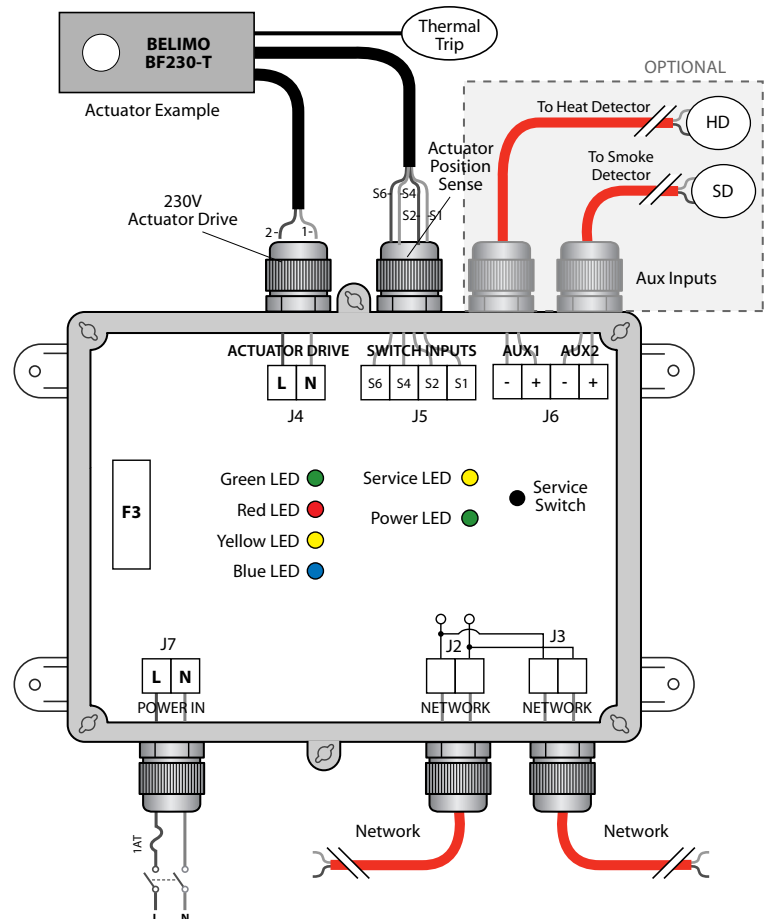

## LED Behaviour

FUNCTION	GREEN	RED	YELLOW	BLUE
Open	On	Off		
Closed	Off	On		
Travelling	Flashing	Flashing		
Fault			Flashing	
Ping				One-shot
Offline	On	On	On	On

Wink function: Service LED flashes for 5s

## Maintenance

250mAT 250 VAC (see F3 on wiring diagram)  
Suggested replacement: Bussman S504 series.

# actionair

Dampers Controls Fancoils

Ruskin Air Management Limited  
www.ruskinuk.co.uk

## LonMark Objects

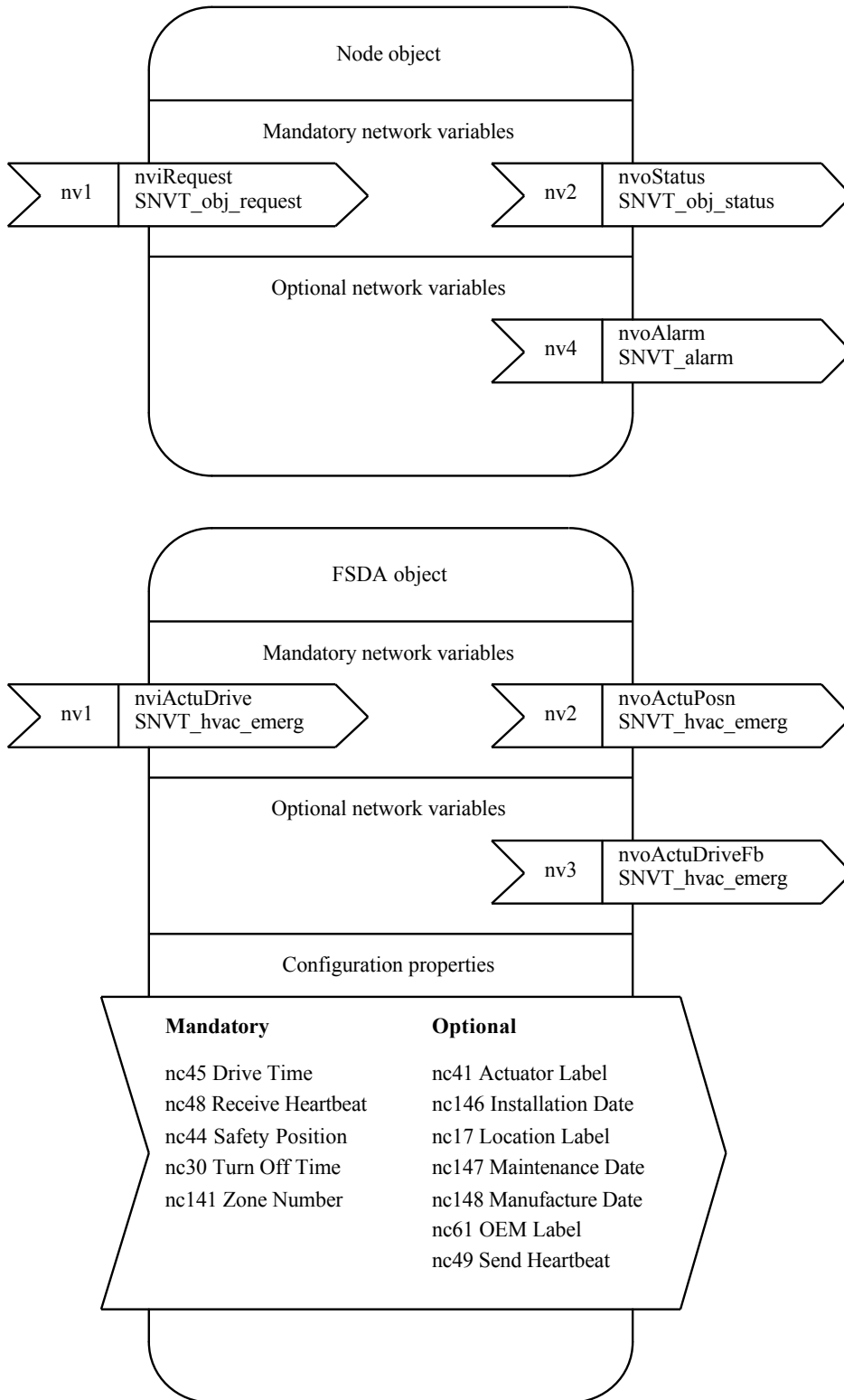

# actionair

Dampers Controls Fancoils

Ruskin Air Management Limited  
www.ruskinuk.co.uk

## LonWorks

Neuron chip	FT 3120-E4 V16, 5 MHz
Transceiver type	TP/FT-10
Service functions	Service pin, service LED and neuron ID self-adhesive tag

## Supply

Input voltage	(230 ± 23) V AC, 50 Hz
Maximum power consumption	5 W

## Output

Contact type	DPCO mechanical relay contacts
Maximum switched load	25 VA

## Inputs

Contact type	Non-isolated dry contacts
Sense current	19 mA at 12 V DC

## Environmental

Operating temperature	-5 °C to 70 °C
Storage temperature	-20 °C to 70 °C
Humidity	25 % RH to 90 % RH at 70 °C
Maximum altitude	2000 m

## Conformance



EMC	EN 50081-1: 1992 EN 61000-6-2: 1999
LVD	EN 61010-1: 2001
LonMark	11001

## Enclosure

Material	ABS base with polycarbonate lid
IP rating	IP 54
Flammability	UL 94V-0
Pollution	Category 2
Dimensions (excl glands)	200 mm x 120 mm x 75 mm (L x W x D)
Dimensions (incl glands)	200 mm x 170 mm x 75 mm (L x W x D)

Note: Optional HSFDI available at 300°C for 1 hour applications. Contact Actionair for details.

## Symbols

-  Complies with European standards
-  IEC 60417-5172 Equipment protected throughout by DOUBLE INSULATION
-  Complies to LonMark Interoperability Guidelines (ISO 7000-0434)

**WARNING: The responsible body shall be made aware that, if the equipment is used in a manner not specified by the manufacturer, the protection provided by the equipment may be impaired.**

LonWorks, LonMark, LonMaker and the 3150 are trademarks of Echelon Corporation registered in the United States and other countries. All other trademarks are acknowledged.

## Ruskin Air Management Limited

South Street, Whitstable, Kent  
CT5 3DU England.  
Tel: 01227 276100  
Fax: 01227 264262  
Email: sales@actionair.co.uk  
Website: www.actionair.co.uk

actionair  
Dampers Controls Fancoils