

actionair

Dampers Controls Fancoils

Ruskin Air Management Limited
www.ruskinuk.co.uk



ALWAYS READ THIS DOCUMENT
BEFORE INSTALLATION. PLEASE
RETAIN FOR FUTURE REFERENCE.

This product forms part of a life safety system. Failure to correctly store, handle, install and maintain the product will directly put at risk the lives of the occupants and the fabric of the building.

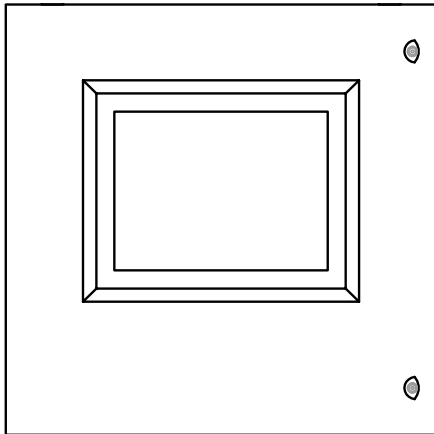

Installation Instructions and Datasheet

Safeguard Panel

actionair

Dampers Controls Fancoils

Ruskin Air Management Limited
www.ruskinuk.co.uk

Mounting

- Only use the mounting brackets provided.
- The unit should have a minimum side clearance of 150 cm as shown across.
- The height of the unit above the floor level should be chosen so that the centre of the PC is just above normal eye level (approximately 1.5 m).
- The unit should be placed in a naturally vented area and this area should be considered fire safe and free from high levels of shock and vibration.
- Conditions should not arise which may allow the temperature in this area to reach or exceed the operating temperature of the unit.
- Do not locate the unit where access to its internal components and connections are restricted.

WARNING: Observe all health and safety procedures when lifting or moving this equipment.

Preparation

- Only trained and qualified personnel should be allowed to install, replace or service this equipment. Installation should be in accordance with the relevant local safety standards.
- The mains wiring should comply with IEC 60227 or IEC 60245.
- A switch or circuit breaker should be included as part of the installation.
- The switch or circuit breaker should meet the relevant requirements of IEC 60947-1 and IEC 60947-3.
- The switch or circuit breaker should be in close proximity to the equipment and be within easy reach of the operator.
- The switch or circuit breaker should be marked as the disconnecting device for the equipment and should disconnect both poles of the supply.
- The switch or circuit breaker should not interrupt the protected earth conductor.
- This equipment **MUST** be earthed.

Mounting Diagram

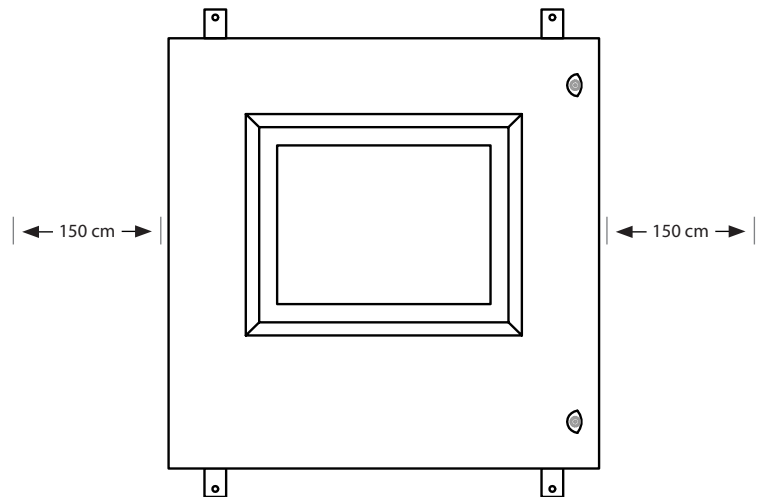

Panel Sizes

There are 4 panel sizes as standard, (H x W x D in mm):

- Size 1: 600 x 600 x 300
- Size 2: 800 x 800 x 300
- Size 3: 1000 x 800 x 300
- Size 4: 1200 x 800 x 300

actionair

Dampers Controls Fancoils

Ruskin Air Management Limited
www.ruskinuk.co.uk

Installation

1. Disconnect the local supply before commencing any work on this equipment.
2. Wire the mains supply feed in accordance with wiring diagram 1. When complete, secure the mains cable using the cable gland.
3. Wire the incoming mains cable in accordance with wiring diagram 2.
4. Wire the incoming live (brown) and neutral (blue) wires to the mains terminal.
5. Connect the incoming earth (green and yellow) wire to the protected earth stud using a ring connector. This connector must be fitted and secured independently using the shake proof washer and nut provided. The floating panel earth wire should be connected on top of this using the additional shake proof washer and nut provided.
6. The mains cable should be fitted in such a manner that, should the cable be subject to strain, the earth wire would be the last wire to break loose.
7. For run/standby installations, wire the standby panel to the run panel in accordance with wiring diagram 3.
8. Finally, the mains wires should be tie wrapped to prevent slippage. Once wiring is complete, apply power to the equipment.

Wiring Diagram 1 (Mains supply feed)

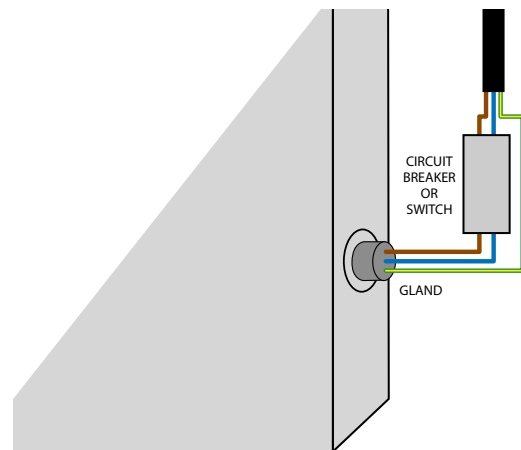

Wiring Diagram 2 (Incoming mains cable)

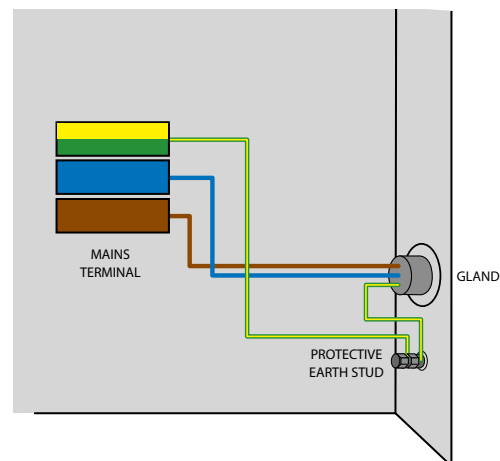

Wiring Diagram 3 (Run/Standby Installations)

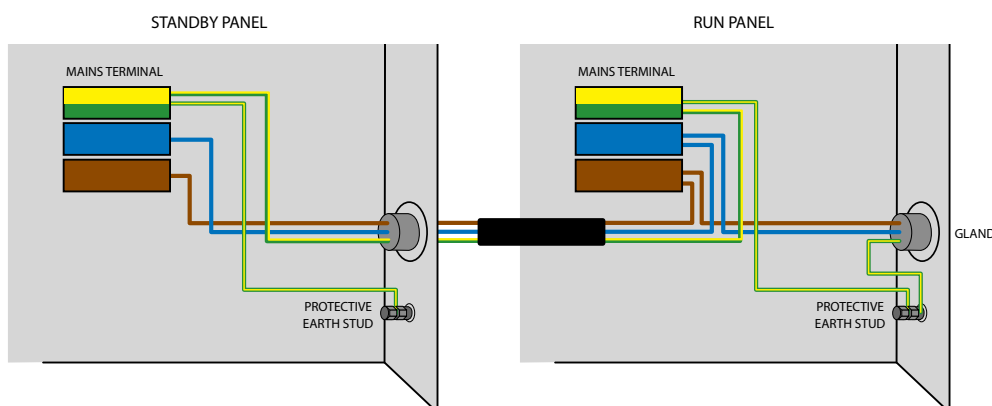

actionair

Dampers Controls Fancoils

Ruskin Air Management Limited
www.ruskinuk.co.uk

Inputs

- The volt free input terminals are numbered 201, 202, 203, etc.
- Wire the first input as shown across and repeat for subsequent inputs.
- Please note that inputs are not optically isolated.
- The input cable diameter should be 1mm² or 1.5mm²
- Limit cable runs to 100m and avoid running input cables near sources of mains or noisy environments.

Outputs

- The relay output terminals are numbered 401, 402, 403, etc.
- Wire the first output as shown across and repeat for subsequent outputs.
- It is the user's responsibility to ensure the switched equipment is adequately protected.
- As a precautionary measure, a standard 1AT fuse is used to protect each output irrespective of it switching 24 V or mains. The value of this fuse may have to be modified in accordance with the user's requirements. The user is responsible for the replacement policies of any fuses whose value deviates from the standard 1 AT fuse supplied.
- The non-fused terminals 401, 403, 405, etc. should be regarded as the output terminals to the switched equipment.
- The fused terminals 402, 404, 406, etc. should be regarded as the input terminals from the switched equipment. The two terminal wires from each output should be tie wrapped together to prevent slippage.

Maintenance

Mains terminal fuse replacements:

Panel sizes 1-2: 1AT 250 VAC

Panel sizes 3-4: 2AT 250 VAC

Output terminal fuse replacement: 1AT 250 VAC

Suggested replacement: Bussman S504 series.

Input Wiring

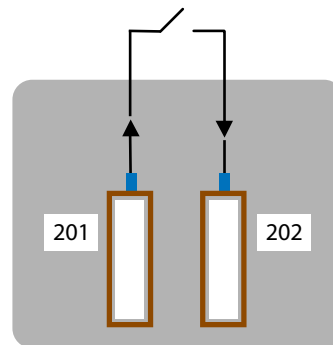

INPUT	TERMINAL NUMBER
INPUT 1	201, 202
INPUT 2	203, 204
ETC.	

Output Wiring

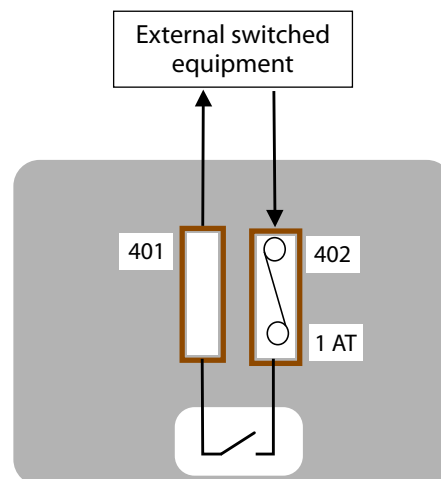

OUTPUT	FEED (FUSED) TERMINAL	RETURN TERMINAL
Output 1	402	401
Output 2	404	403
ETC.		

actionair

Dampers Controls Fancoils

Ruskin Air Management Limited
www.ruskinuk.co.uk

Networks

- The network terminals are numbered 101, 102... These free topology networks are internally terminated.
- Wire the first network as shown across and repeat for subsequent networks.
- It is recommended that the network cables are not run alongside any high voltage or high frequency sources. Also, network cables must not be mixed on an individual network as they have very different electrical characteristics and could render the system unreliable.

Network Wiring

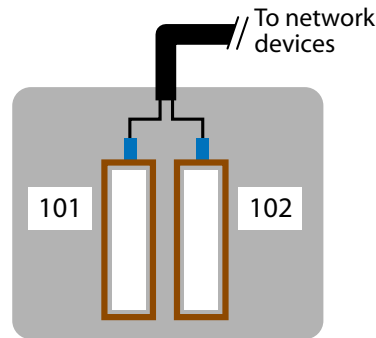

NETWORK	TERMINAL NUMBER
NETWORK 1	101, 102
NETWORK 2	103, 104
ETC.	

Specification

Supply

Input voltage	(230 ± 23) V AC, 50 Hz
Maximum power consumption	750 VA

Inputs

Contact type	Non-isolated dry contacts
Sense current	15 mA at 12 V DC

Outputs

Contact type	SPCO mechanical relay contacts
Maximum switched load	3 A at 230 V AC 3 A at 30 V DC

☞ Complies with European standards

Environmental

Operating temperature	0 °C to 40 °C
Storage temperature	-15 °C to 45 °C
Humidity	80 % RH to 31 °C decreasing linearly to 50 % RH at 40 °C
Maximum altitude	2000 m

Conformance

EMC	EN 55011: 1999 + A2: 2002 EN 61000-6-1: 2001
LVD	EN 61010-1: 2001

WARNING: The responsible body shall be made aware that, if the equipment is used in a manner not specified by the manufacturer, the protection provided by the equipment may be impaired.

Ruskin Air Management Limited

South Street, Whitstable, Kent
CT5 3DU England.
Tel: 01227 276100
Fax: 01227 264262
Email: sales@actionair.co.uk
Website: www.actionair.co.uk

actionair
Dampers Controls Fancoils