

actionair

Dampers Controls Fancoils

Ruskin Air Management Limited
www.ruskinuk.co.uk



ALWAYS READ THIS DOCUMENT
BEFORE INSTALLATION. PLEASE
RETAIN FOR FUTURE REFERENCE.

This product forms part of a life safety system. Failure to correctly store, handle, install and maintain the product will directly put at risk the lives of the occupants and the fabric of the building.

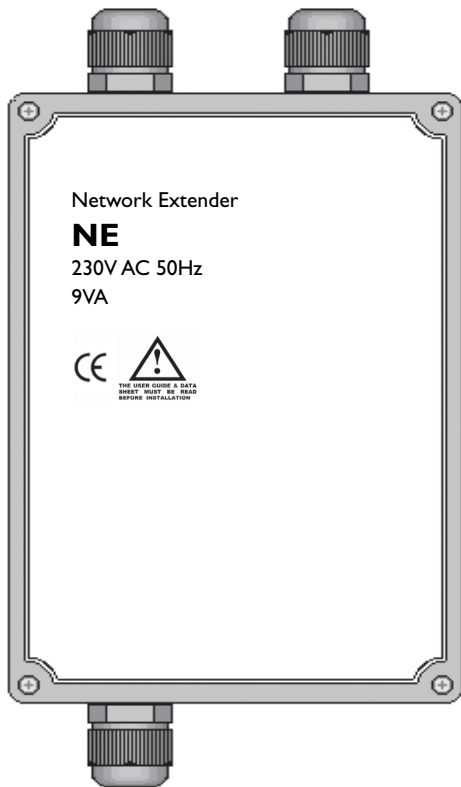

The Safeguard Network Extender is used to manage network traffic, increase the total number of devices or increase the amount of cabling in a system.

The Safeguard Network Extender is terminated for ease of installation.



ELECTROSTATIC SENSITIVE DEVICE

Installation Instructions and Datasheet

Network Extender (230V)

actionair

Dampers Controls Fancoils

Ruskin Air Management Limited
www.ruskinuk.co.uk

Dimensions and Mounting

The compact and robust design of the NE enclosure allows the unit to be mounted to a duct, block wall or stud wall.

Ensure the NE is accessible for future maintenance purposes.

Please note: Do not drill the enclosure as this will affect its IP rating.

Mounting Diagram

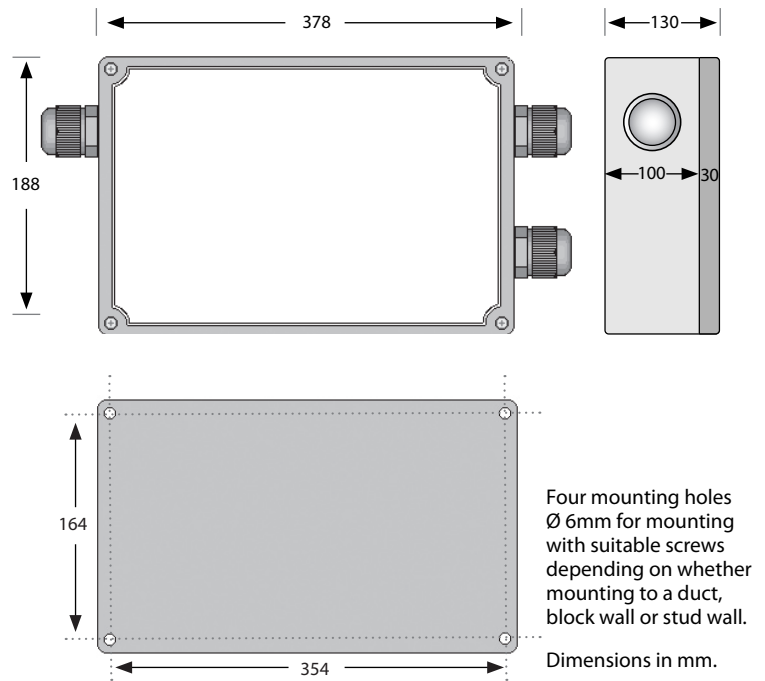

actionair

Dampers Controls Fancoils

Ruskin Air Management Limited
www.ruskinuk.co.uk

Preparation

- Only trained and qualified personnel should be allowed to install, replace or service this equipment. Installation should be in accordance with the relevant local safety standards.
- The connectors can accommodate cable diameters up to 2.5mm². It is recommended that all wires be crimped to ease installation and replacement of the product.
- The mains wiring should comply with IEC 60227 or IEC 60245.
- A switch or circuit breaker should be included as part of the installation.
- The switch or circuit breaker should meet the relevant requirements of IEC 60947-1 and IEC 60947-3.
- The switch or circuit breaker should be in close proximity to the equipment and be within easy reach of the operator.
- The switch or circuit breaker should be marked as the disconnecting device for the equipment and should disconnect both poles of the supply.
- The switch or circuit breaker should not interrupt the protected earth conductor.
- This equipment **MUST** be earthed.

Installation

1. Disconnect the local supply before commencing any work on the NE.
2. Wire the NE in accordance with the wiring diagram shown across.
3. The mains cable should be fitted in such a manner that, should the cable be subject to strain, the earth wire would be the last wire to break loose.
4. The mains cable should be secured using the cable gland provided and tie wrapped to prevent slippage.
5. It is recommended that the network cables are not run alongside any high voltage or high frequency sources. Also, network cables must not be mixed on

Wiring Diagram (NE in enclosure without lid fitted)

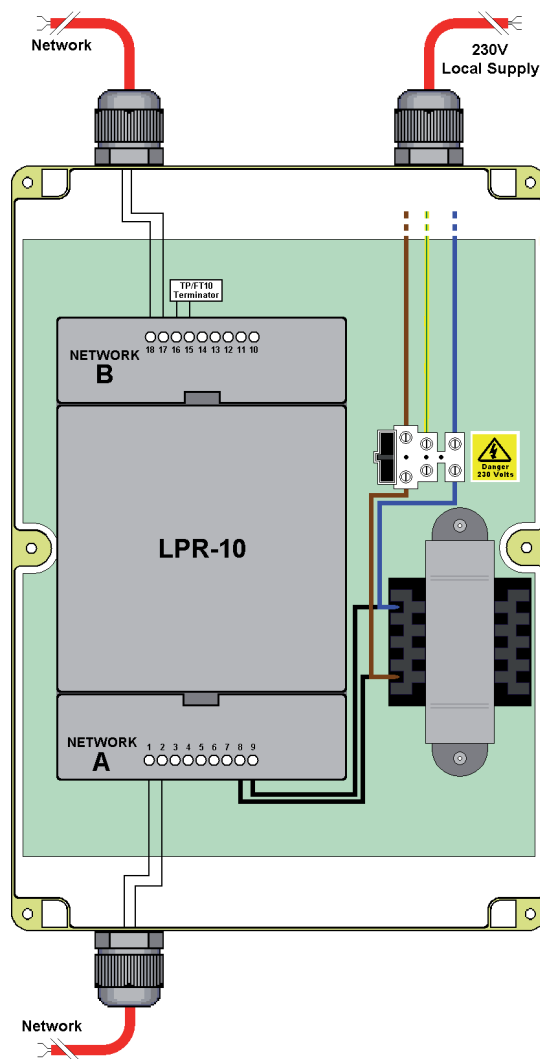

an individual network as they have very different electrical characteristics and could render the system unreliable.

6. Once wiring is complete, apply power to the NE. The green power LED should illuminate to indicate the presence of power.
7. The NE is now ready to be configured using a standard LonWorks tool such as LonMaker or the Safeguard system.

Maintenance

Mains terminal fuse replacement: 250mAT 250 VAC
Suggested replacement: Bussman S504 series.

actionair

Dampers Controls Fancoils

Ruskin Air Management Limited
www.ruskinuk.co.uk

Specification

LonWorks

Near channel transceiver type	TP/FT-10
Far channel transceiver type	TP/FT-10 (terminated)
Service functions	Service pin, service LED and neuron ID self-adhesive tag

Supply

Input voltage	(230 ± 23) V AC, 50 Hz
Maximum power consumption	9 VA

Environmental

Operating temperature	-5 °C to 50 °C
Storage temperature	-20 °C to 50 °C
Humidity	80 % RH to 31 °C decreasing linearly to 50 % RH at 40 °C
Maximum altitude	2000 m

Conformance

EMC	EN 55011: 1999 + A2: 2002 EN 61000-6-1: 2001
LVD	EN 61010-1: 2001

Enclosure

Material	Polycarbonate
IP rating	IP 54
Flammability	UL 94V-0
Pollution	Category 2
Dimensions (excl glands)	278 mm x 188 mm x 130 mm (L x W x D)
Dimensions (incl glands)	328 mm x 188 mm x 130 mm (L x W x D)

Ⓒ Complies with European standards

WARNING: The responsible body shall be made aware that, if the equipment is used in a manner not specified by the manufacturer, the protection provided by the equipment may be impaired.

LonWorks, LonMark and the LonMaker are trademarks of Echelon Corporation registered in the United States and other countries. All other trademarks are acknowledged.

Ruskin Air Management Limited

South Street, Whitstable, Kent
CT5 3DU England.
Tel: 01227 276100
Fax: 01227 264262
Email: sales@actionair.co.uk
Website: www.actionair.co.uk

actionair
Dampers Controls Fancoils