

# **Drywall or Masonry Wall & Rockwool BATT penetration seal - CSS**

## **Health and safety**

This process must be undertaken by competent persons. More than one person may be required to ensure the safe handling of large dampers and other materials.

Use must be made of access equipment to ensure unsafe practices are not used to approach walls or difficult access areas.

Standard site PPE should be used (minimum steel toe cap boots, hard hat); together with any protective eyewear, gloves and masks, when drilling or cutting is being undertaken. The latter should also be used when handling the wall construction materials, as defined by the material suppliers. If loud equipment is being used, hearing protection should be used.

All waste materials should be collected and disposed of as defined by the relevant supplier.

## **Damper installation method**

- 1) Mark out the hole on the partition and cut it out, cutting the top and bottom edges first to maintain stability
- 2) Frame out the hole with stud and track and cover this with 2 layers of board. Finish edges with joint filler.
- 3) For Masonry walls commence from item 4.
- 4) Make sure the area within the aperture is free from any debris and remove any dust.
- 5) Where the coated BATT will contact the surrounding aperture apply Rockwool acoustic intumescent sealant to the outer edges of the BATT. Where two coated BATTs are in contact, use Rockwool fire pro glue as the joint adhesive. In both cases ensure that an even cover is achieved over the entire thickness of the BATT.
- 6) Continue installation of Rockwool ablative coated BATT, until aperture is completely filled.
- 7) Apply a bead of Rockwool acoustic sealant to both sides of the wall, approximately 15mm wide, around perimeter of the aperture between dry wall and BATT, ensuring that any gaps between the BATT and surrounding edges are fully filled.
- 8) Allow 12 hours for BATT penetration seal to cure.
- 9) Mark and cut circular hole into BATT, Install the damper and fasten one Installation Flange so that the blade in its closed position is in the centre of the wall
- 10) Fit the remaining Installation Flange

## **Actuator**

- 1) The control mode/actuator is supplied fitted. This should be checked for damage and the manual operation of the damper checked.
- 2) Check that the Electrical Thermal Release (ETR) is still firmly connected through the damper case. If it is not, the actuator/control mode may not work electrically.
- 3) A special feature of the Actionair CSS modes is that they may be adjusted from pointing straight out along the duct (standard configuration) through 90° to point either up or down if required.
- 4) The mode should be wired into the system using the site wiring detail, plus the details shown on the label.

Note: If the mode/actuator fitting instructions are missing, please contact the Actionair sales office for a new copy.

## **Commissioning**

The procedure detailed under periodic maintenance should be followed

## **Periodic maintenance**

### **As detailed in BS 9999:2008**

- 1) For dampers this is generally at least once per year for units with spring operation.
- 2) Units operating in dust laden atmospheres, should be checked more often to suit the severity of the system
- 3) Units associated with systems may be required to be checked, as part of the system, as often as once per week or month to ensure ongoing confidence in the life safety system. This may be seen as analogous to fire alarm systems.

## **Procedure**

- 1) The units should be carefully inspected and cleaned of dust and debris
- 2) The units should then be lubricated with a light oil, by wiping this over all the surfaces
- 3) The mode should be operated to ensure that it is moving the blades from open to closed and the reverse.
- 4) If the micro switches (in the mode) are being used, it should be checked that they are actually indicating that the blades are open or closed. This is done by running a cycle and checking both the blades (open and closed) and the indication that the micro switches are feeding back to.

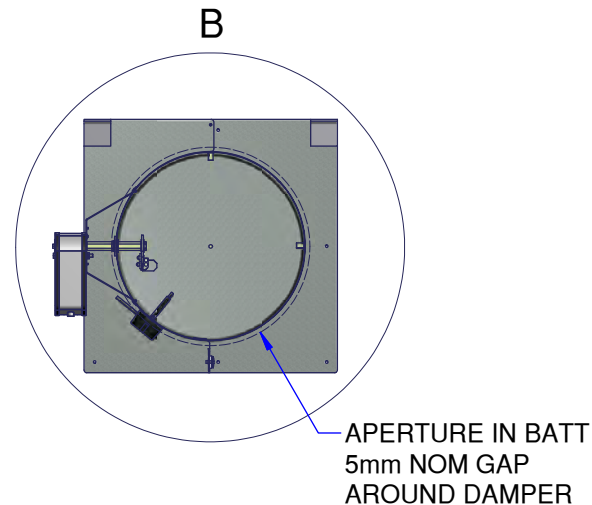
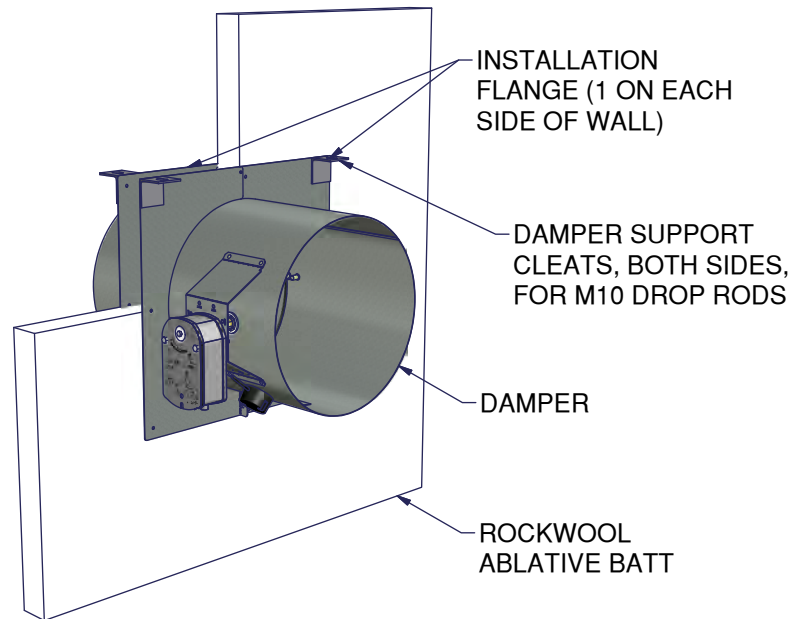
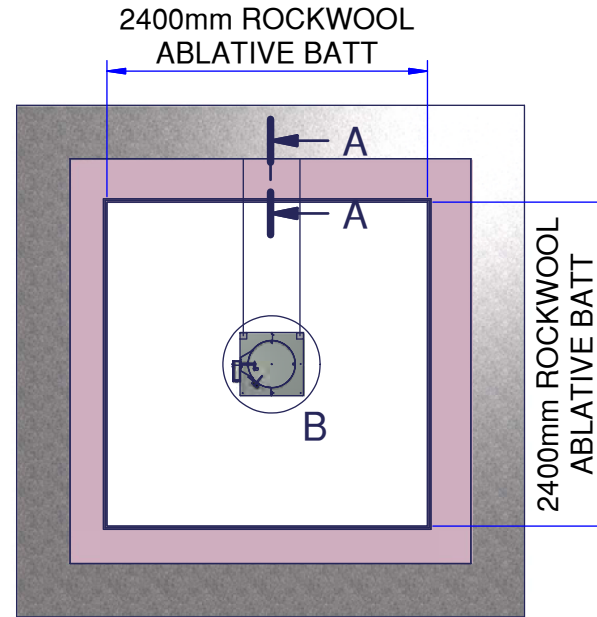
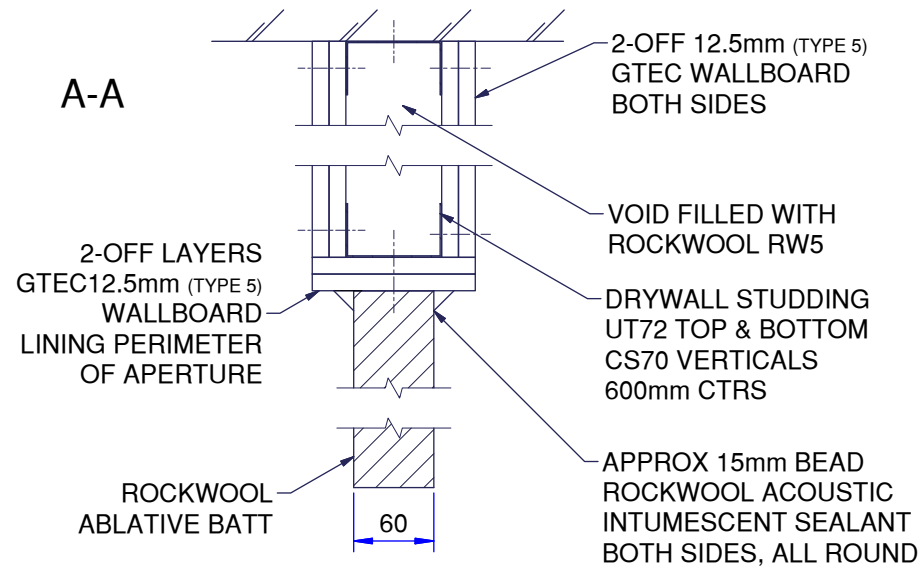

IF YOUR PROPOSED INSTALLATION DETAIL DIFFERS FROM THAT SHOWN, PLEASE DISCUSS THIS WITH THE BUILDING CONTROL AUTHORITY (BCA) USING THIS DOCUMENT AND THE ASSOCIATED FIRE TESTS, ASSESSMENTS AND OTHER DOCUMENTS SHOWN BELOW, SO THE BCA CAN DECIDE WHETHER YOUR PROPOSED METHOD DIFFERS SUFFICIENTLY FOR IT TO BE UNACCEPTABLE TO THEM (THE BCA)

**APPLICABLE ASSESSMENT**  
**BS EN1366-2**  
**BRE CC270714C**

ACTIONAIR REF: AAF10721

**120 MINUTES**  
**FIRE RESISTANCE**  
**INTEGRITY & LEAKAGE**

**www.actionair.co.uk**  
 VERTICAL APPLICATION  
 CIRCULAR SMOKE SHIELD  
 DRY WALL & ABLATIVE BATT  
 DAMPER SIZE RANGE:  
 Ø100mm - Ø355mm

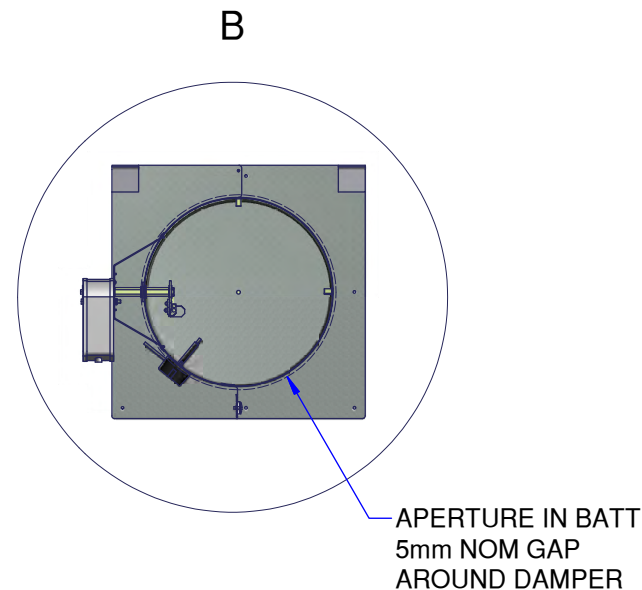
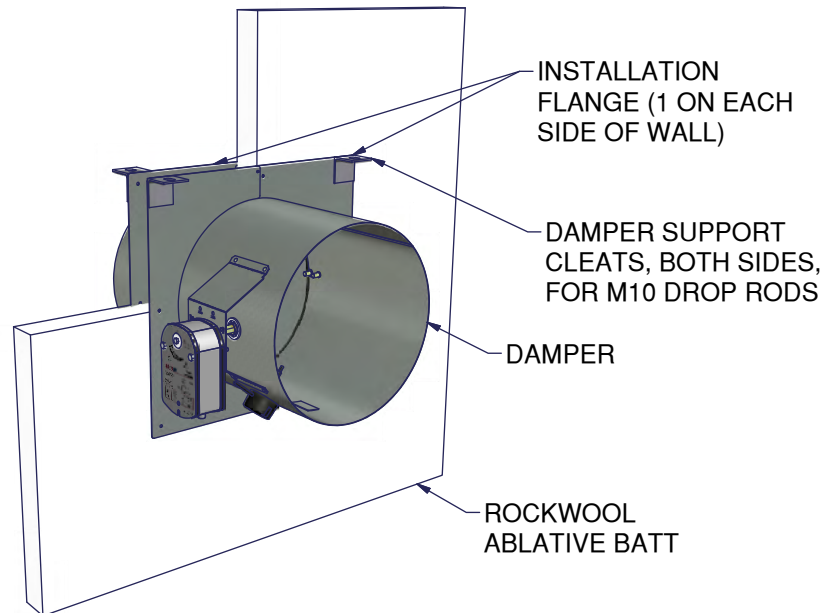
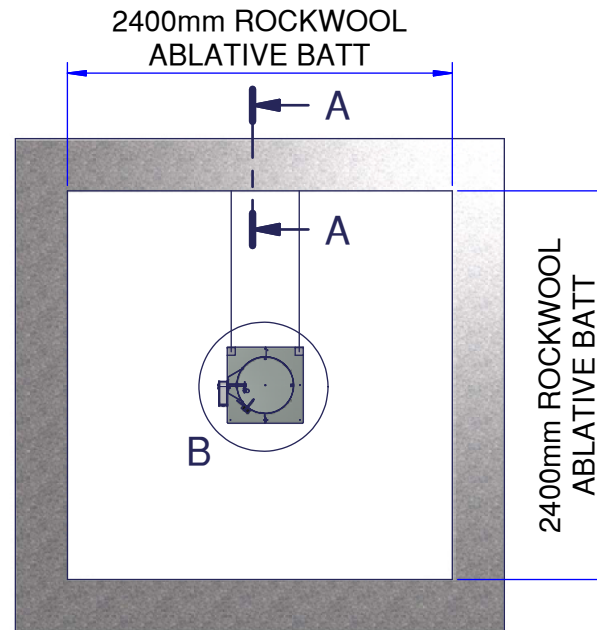
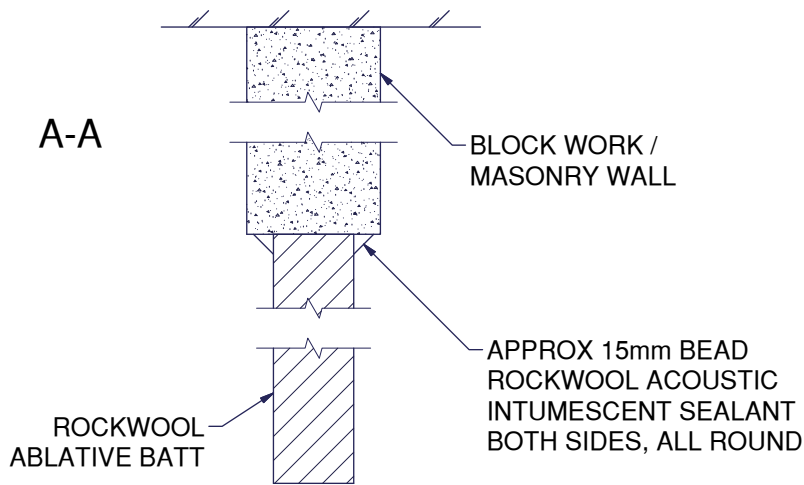

CONNECTING DUCTWORK OMITTED FOR CLARITY

IF YOUR PROPOSED INSTALLATION DETAIL DIFFERS FROM THAT SHOWN, PLEASE DISCUSS THIS WITH THE BUILDING CONTROL AUTHORITY (BCA) USING THIS DOCUMENT AND THE ASSOCIATED FIRE TESTS, ASSESSMENTS AND OTHER DOCUMENTS SHOWN BELOW, SO THE BCA CAN DECIDE WHETHER YOUR PROPOSED METHOD DIFFERS SUFFICIENTLY FOR IT TO BE UNACCEPTABLE TO THEM (THE BCA)

APPLICABLE ASSESSMENT  
BS EN1366-2  
BRE CC270714C

ACTIONAIR REF: AA/F10722

**120 MINUTES**  
FIRE RESISTANCE  
INTEGRITY & LEAKAGE

**www.actionair.co.uk**  
VERTICAL APPLICATION  
CIRCULAR SMOKE SHIELD  
MASONRY WALL & ABLATIVE BATT  
DAMPER SIZE RANGE:  
Ø100mm - Ø355mm