

XNNN00599
M5 – 3P CMS (230V)
Mode 5 Three Position Control and Monitoring Station

Installation and Operating Instructions

UNPACKING AND INSPECTION

- If the equipment appears damaged in any way, return it to sales outlet in its original packaging. No responsibility for damage arising from the use of non-approved packaging will be accepted.
- Ensure all items and accessories specified are present. If not, contact your sales outlet or local Ruskin Air Management agent.

SAFETY SYMBOLS

Retain these instructions.

The following symbols mean: w



Warning: read instructions to understand possible hazard



Danger: electrical shock hazard

Caution: Read these operating instructions fully before use.

SAFETY WARNINGS

Always observe the following safety precautions: -

- Always disconnect the equipment from the power supply and ancillary equipment before moving.
- This equipment is for use in moderate climates only. NEVER use the equipment in damp or wet conditions.
- Avoid excessive heat, humidity, dust & vibration.
- Do not use where the equipment may be subjected to dripping or splashing liquids.
- Always use wire with insulation suitable for -5°C to 55°C .
- Ensure that the circuit isolator is easily accessible to allow the unit to be switched off.

This equipment contains no user-serviceable parts. Refer all repairs to qualified service personnel.





GENERAL INFORMATION

The M5-3P-CMS (230V) is used to provide control and monitoring of the Actionair Mode 5-3P Control Mode. The unit provides:

- Local set point control.
- Local (LED) status.
- Local damper travelling indication.
- Local test switches.
- External BMS INPUT for damper SET POINT.
- External RESET OVERRIDE input for damper RESET.
- External FIRE ALARM input for damper fail-safe RELEASE.
- Volt-free outputs providing SET POINT, RESET and RELEASE status.

Operating voltage - 230 Volt $\pm 10\%$ ac 50Hz or 60Hz

One M5-3P-CMS (230V) is used to operate one Mode 5-3P control mode only.

DIMENSIONS

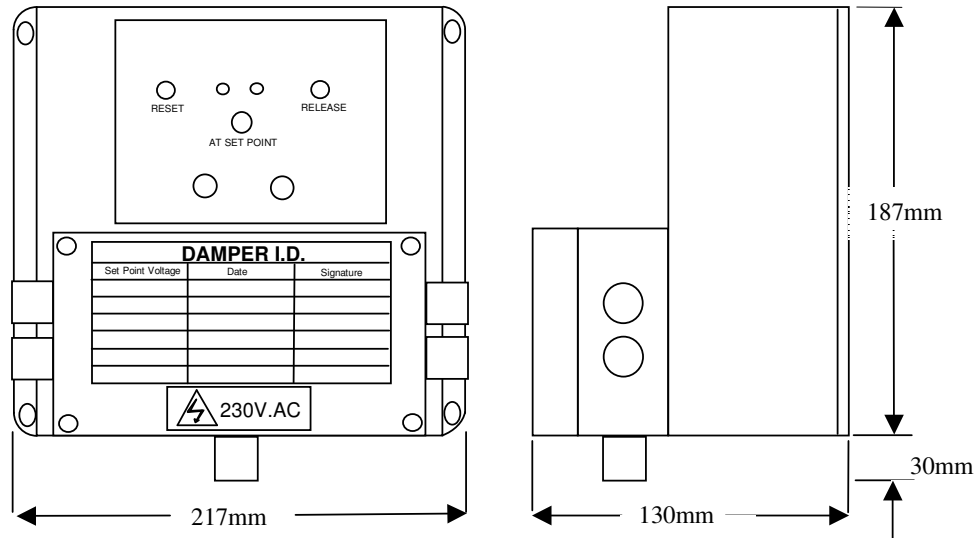

Fig 1. Dimensions of M5-3P CMS (230V)

INSTALLTION

Surface mounting

1. Position and level the unit on to a suitable flat surface (such as a wall) and use a pencil to mark the mounting hole positions.
2. Remove the unit from the wall, drill four appropriate holes for the type of fastening selected to mount the unit.
3. Fix unit securely to the wall using appropriate fixings (fig.2).
4. Remove front cover (four screws) and safety guard (four screws). Retain screws/washers.
5. Ensure that only specified cables are used for interconnection of equipment.
 - a. Max outer cable diameter to gland 8.5mm
 - b. Max inner core cross sectional area (CSA) to suit terminals 1.5mm².
6. Connect as per wiring detail on inside face of front cover. Unit MUST be earthed but other optional connections may be omitted.
7. If BMS INPUT option is used then remove factory set link on BMS Input terminals (terminals 21 & 22).
8. If fire alarm option is not used then FIRE ALARM terminals MUST be linked (terminals 1 & 2).
9. Replace safety guard and front cover.
10. Ensure all cables are routed safely. Avoid sharp bends.

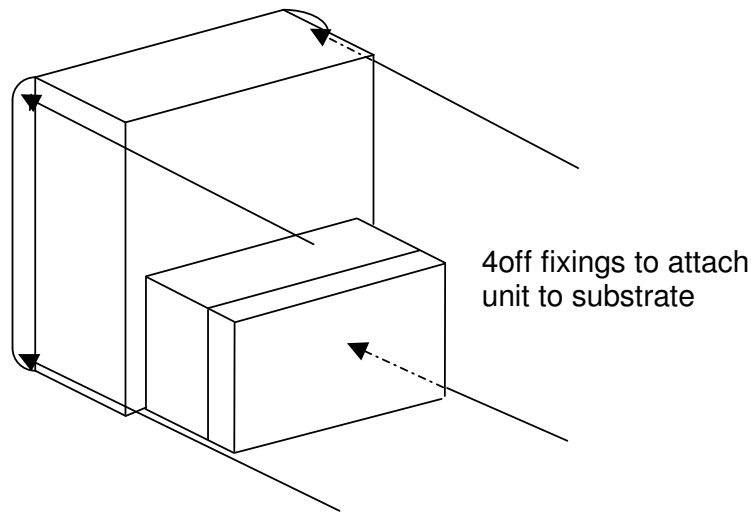
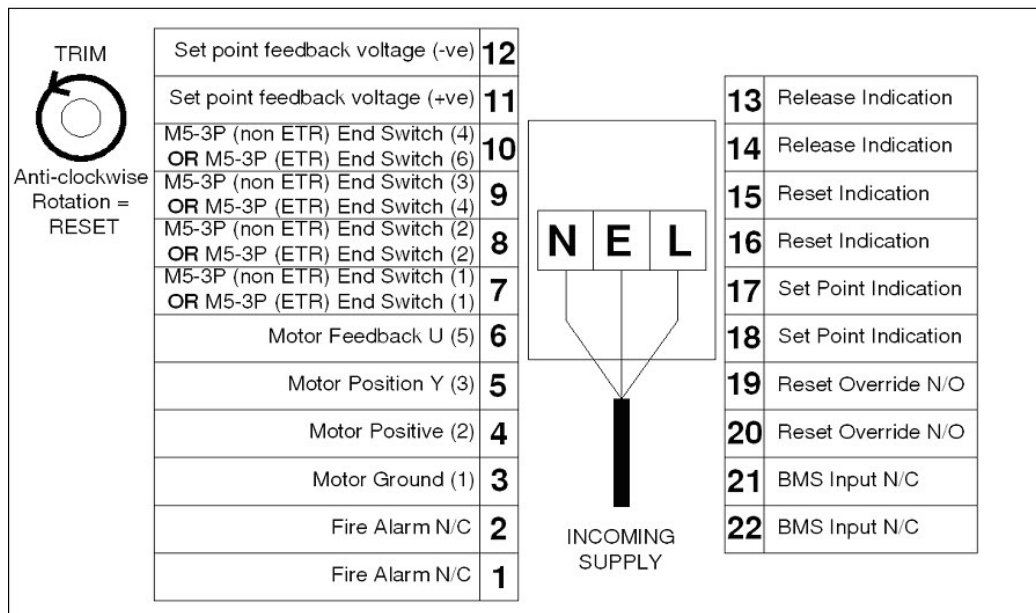

Fig 2. Mounting of the unit onto the wall

WIRING



The NON-ETR Control Mode version has 4 signal wires, whilst the ETR version has 6 wires, two of which (nos 3 and 5) are not used and must be isolated.



CAUTION

Ensure that all wiring is correctly completed before applying power! Do not connect/disconnect wires when the unit is powered. Do not unscrew the unit from the wall when the power is on.

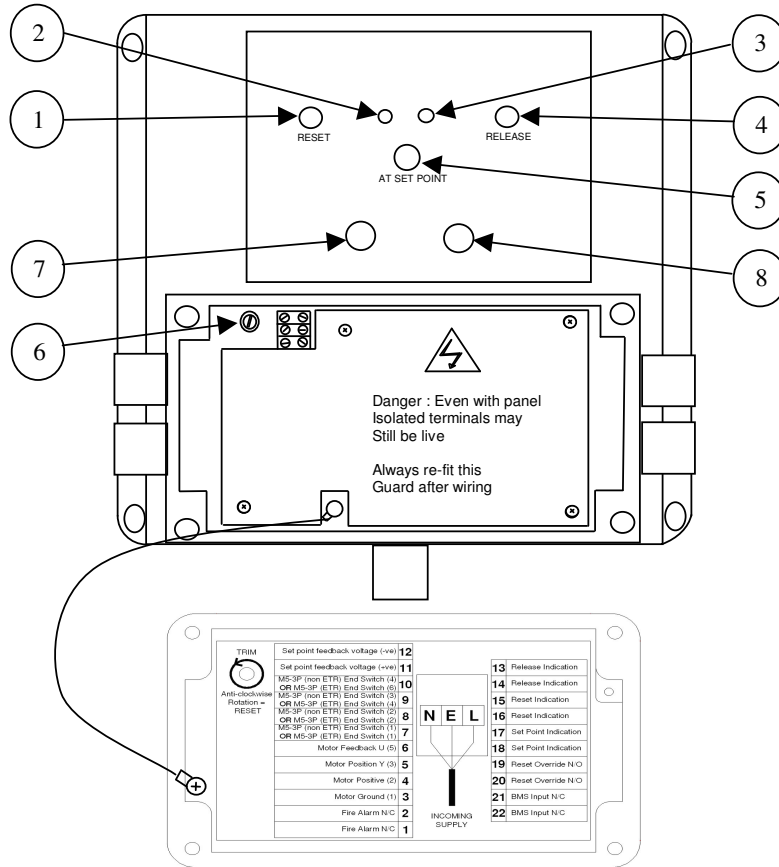

Fig 3. Front panel details

OPERATION (refer to fig. 3)

Note: - Allow time for damper to travel to set positions (up to 150 seconds).

Applying power to the unit will move the associated damper to the SET POINT (5) set by TRIM potentiometer (6) providing both the Fire Alarm and BMS input contacts are closed.

Two push buttons (7&8) are provided for testing. Each button should be held until the damper reaches the desired position as indicated by the relevant LED illuminating (1or4). Pressing both buttons at the same time will cause the unit to travel towards the RELEASED position.

HINT: The SET POINT may be “chased” by using the test buttons to set an airflow, releasing them, and then adjusting the TRIM potentiometer until the SET POINT LED illuminates. The buttons must be released otherwise the LED will not illuminate.

When the damper reaches the SET POINT the green LED illuminates. There are two additional LEDs, one red (4) to indicate fully RELEASED, and one yellow (1) to indicate fully RESET.

Two additional small red LEDs (2&3) indicate that the unit is trying to move towards RESET or RELEASED. Either of these will remain illuminated until the SET POINT is reached. (In the case of overriding or testing, one of these will illuminate in the opposite direction to which the unit is actually moving and will remain illuminated until the unit returns to set point.

Fire Alarm	BMS Input	Reset Override	Damper Status
0	0	0	Released
0	0	1	Released
0	1	0	Released
0	1	1	Released
1	0	0	Released
1	0	1	Reset
1	1	0	Set Point
1	1	1	Reset

0 – Open contact

1 – Closed contact

The damper will also spring return to the RELEASED position if:

The power is lost,

Or the ETR fuse /test switch operates.

Test that the unit functions as per your requirements.

Local TRIM potentiometer is a multi turn device that turns infinitely at each end of the range. First few turns of each end have no effect on adjustment. Anticlockwise rotation moves the control mode towards RESET.

Fault Finding

NOTE: It is possible to have RELEASED and SET POINT LEDs illuminated simultaneously due to Control Mode end switch tolerances. Similarly the same applies for RESET.

If the unit does not function as expected, the following table will provide suggested actions:-

Fault	Suggested action
No indication is shown on unit.	<ul style="list-style-type: none"> ✓ Check 230V supply is connected to unit. ✓ Check Mode 5-3P Control Mode is correctly connected to unit.
Unit shows RELEASED indication With no SET POINT indication	<ul style="list-style-type: none"> ✓ Check Fire Alarm contact closed. [link if not used]. ✓ Check BMS Input contact closed. [link if not used]. ✓ Rotate TRIM anti-clockwise until set point illuminates.
Unit shows RESET indication With no SET POINT indication	<ul style="list-style-type: none"> ✓ Check Reset Override contact open. ✓ Rotate TRIM clockwise until set point illuminates.

COMMISSIONING / MAINTENANCE

The unit is maintenance free, and contains no serviceable parts.
The M5-3P CMS (230V) should be commissioned

Set up

When the required damper set position is obtained the control mode feedback d.c.voltage can be measured between terminals 11 & 12 and recorded on the front cover label.

It is recommended that it is tested annually as follows:

- Check operation of controller/damper system via pressing and holding Reset and Release push buttons independently and observing LED status and damper blades travel to test position.
- Remove the BMS input contact to the unit to check status and that damper fully releases.
- Reinstate BMS input contact and damper returns to set point position.
- Instate the BMS Override contact to the unit to check status and that damper fully resets.
- Remove BMS Override contact and damper returns to set point position.
- Remove the Fire Alarm contact to the unit to check status and that damper fully releases.
- Reinstate Fire Alarm contact and damper returns to set point position.
- Light cleaning of surface of unit using a damp cloth. Do not to allow moisture to penetrate unit. Do not use any form of solvents.
- The attached damper should also be subject to regular operational checks, cleaning and lubrication (as instructed by the manufacturer) in accordance with local requirements or 12 monthly intervals.

TECHNICAL SPECIFICATION

The Mode 5 – 3P CMS (230V) unit is for indoor use only to operate within an ambient temperature range of -5°C to 55°C to a maximum relative humidity of 80%.

Equipment is for operation at installation category II (transient voltages) and pollution degree II in accordance with IEC 664 at altitudes up to 2000 metres.

Overall maximum dimensions including glands are: 187mmW X 217mmH X 217mmD

Approx weight is: 2.6Kg

Supply voltage: A.C. supply of 230V+/-10% Volts~

Power consumption: - 110mA, 80mA (without actuator)

Degree of protection (IP rating): - Not applicable

This product is in accordance with the EMC Directive and Low-Voltage Directive.

This product fulfils the following requirements:

- EN61326: 1997 (+A1/A2/A3)
- Low voltage directive – CE compliant LVD meets EN 61010-1

Ruskin Air Management (*actionair*) Ltd
Joseph Wilson Industrial Estate
South Street
Whitstable
Kent
CT5 3DU
England
Tel: +44(0)1227 276100
Fax: +44(0)1227 264262
Email: sales@actionair.co.uk
Website: www.actionair.co.uk